

R.7

Harmonic filters and EMI



Filtering unit selection guide	R7-11
LCL	
Harmonic filter for power converters	R7-13
LCL-TH	
Harmonic filter for elevators	R7-16
SINUS	
Filter for PWM	R7-18
AFQ	
Multifunction Parallel Active Filter	R7-20
FB3	
Third harmonic blocking filter	R7-22
FB3T	
Third harmonic blocking filter	R7-23
TSA	
Insulation transformer with harmonic filtering	R7-24
EMR	
High-frequency filter	R7-26
VPF	
Power filter	R7-28
VEF, BLC	
Book-type power filter	R7-29
CEM	
Motor-side chokes	R7-31
FAR-Q	
Hybrid absorption filter	R7-32
FARE-Q	
Hybrid absorption filter	R7-35
FAR-H-AP5	
Regulated absorption filter 5th Harmonic absorption	R7-38
FAR-H-AP57	
Regulated absorption filter 5th and 7th Harmonic absorption	R7-40

Harmonic filters and EMI

What are harmonics?

Non linear loads, such as: rectifiers, inverters, speed variators, furnaces, etc. that absorb periodic non-sine wave currents from the network.

Said currents are composed of a fundamental frequency component rated at 50 or 60 Hz, plus a series of overlapping currents, with frequencies that are multiples of the fundamental frequency. This is how we define HARMONICS. The result is a deformation of the current (and, as a consequence, voltage) that has a series of associated secondary effects.

Order	Frequency	Sequence
Fund.	50	↻
2	100	↻
3	150	↑
4	200	↻
5	250	↻
6	300	↑
7	350	↻

Order and behaviour of harmonics

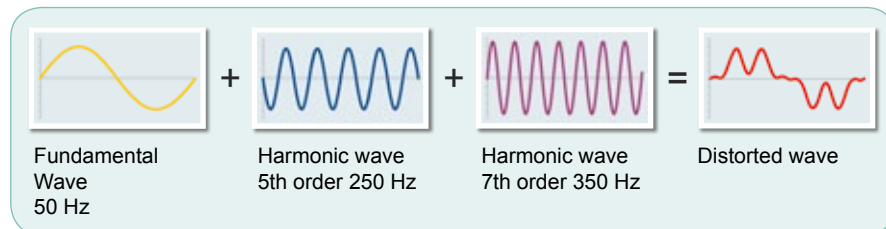

Decomposition of the distorted wave shape

Basic concepts

Some fundamental terms related to harmonics must be defined in order to interpret any measurement and study:

- **Fundamental frequency (f_1):** Frequency of the original wave (50/60 Hz)
- **Order of harmonics (n):** Whole number given by the frequency relationship between a harmonic and the fun-

damental frequency. The order is used to determine the frequency of the harmonic (Example: 5th order harmonic → $5 \cdot 50 \text{ Hz} = 250 \text{ Hz}$)

- **Fundamental component (U_1 or I_1):** 1st order sine-wave component for the development of the Fourier series, with a frequency identical to the original periodic wave.



◦ **Harmonic component (U_n or I_n):** Sine-wave component of the 2nd or higher order for the development of the Fourier series, with a frequency that is a multiple of the original periodic wave in whole numbers.

◦ **Individual distortion rate ($U_n\%$ or $I_n\%$):** Relationship in % between the root mean square of harmonic voltage or current (U_n or I_n) and the root mean square of the fundamental component (U_1 or I_1).

$$U_n\% = \frac{U_n}{U_1} \cdot 100 \quad I_n\% = \frac{I_n}{I_1} \cdot 100$$

◦ **True root mean square (TRMS):** Square root of the sum of the squares of all components of the wave.

◦ **Harmonic residue:** Difference between the total voltage and current and the corresponding fundamental value.

◦ **Total Harmonic Distortion (THD):** Relationship between the root mean square of the harmonic residue of voltage and/or current and the value of the fundamental component.

$$THD(U)\% = \frac{\sqrt{U_2^2 + U_3^2 + U_5^2 + \dots}}{U_1}$$

$$THD(I)\% = \frac{\sqrt{I_2^2 + I_3^2 + I_5^2 + \dots}}{I_1}$$

Most common harmonics

The following table shows the most common loads that generate harmonics, as well as the wave shape of the current consumed and their harmonic spectrum.

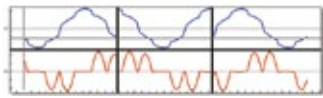
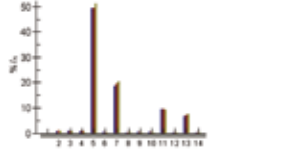
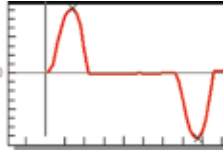
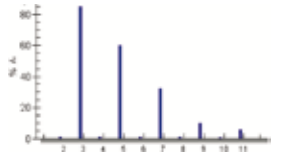
Type of load	Wave shape	Harmonic spectrum THD(I)
6-pulse converters: <ul style="list-style-type: none"> • Speed variators • UPS • Three-phase rectifiers • Electrolysis and dip converters 		
<ul style="list-style-type: none"> • Discharge lamps • Single-phase converters • Lighting lines • Computer lines • Image and sound equipment 		

How to deal with anomalies caused by harmonics or alterations

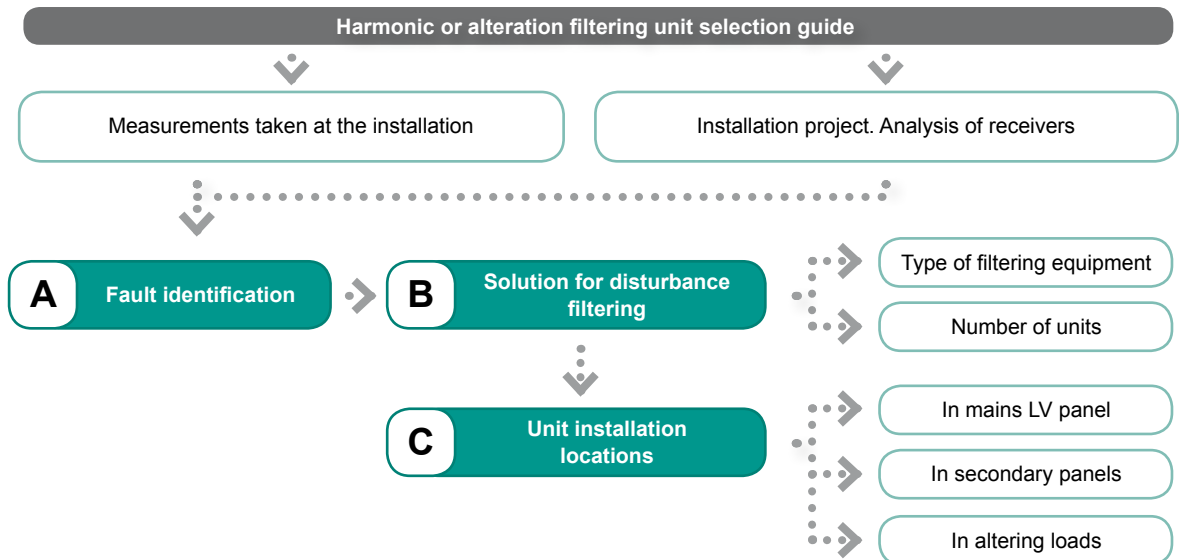

A

Identification of the type of anomaly

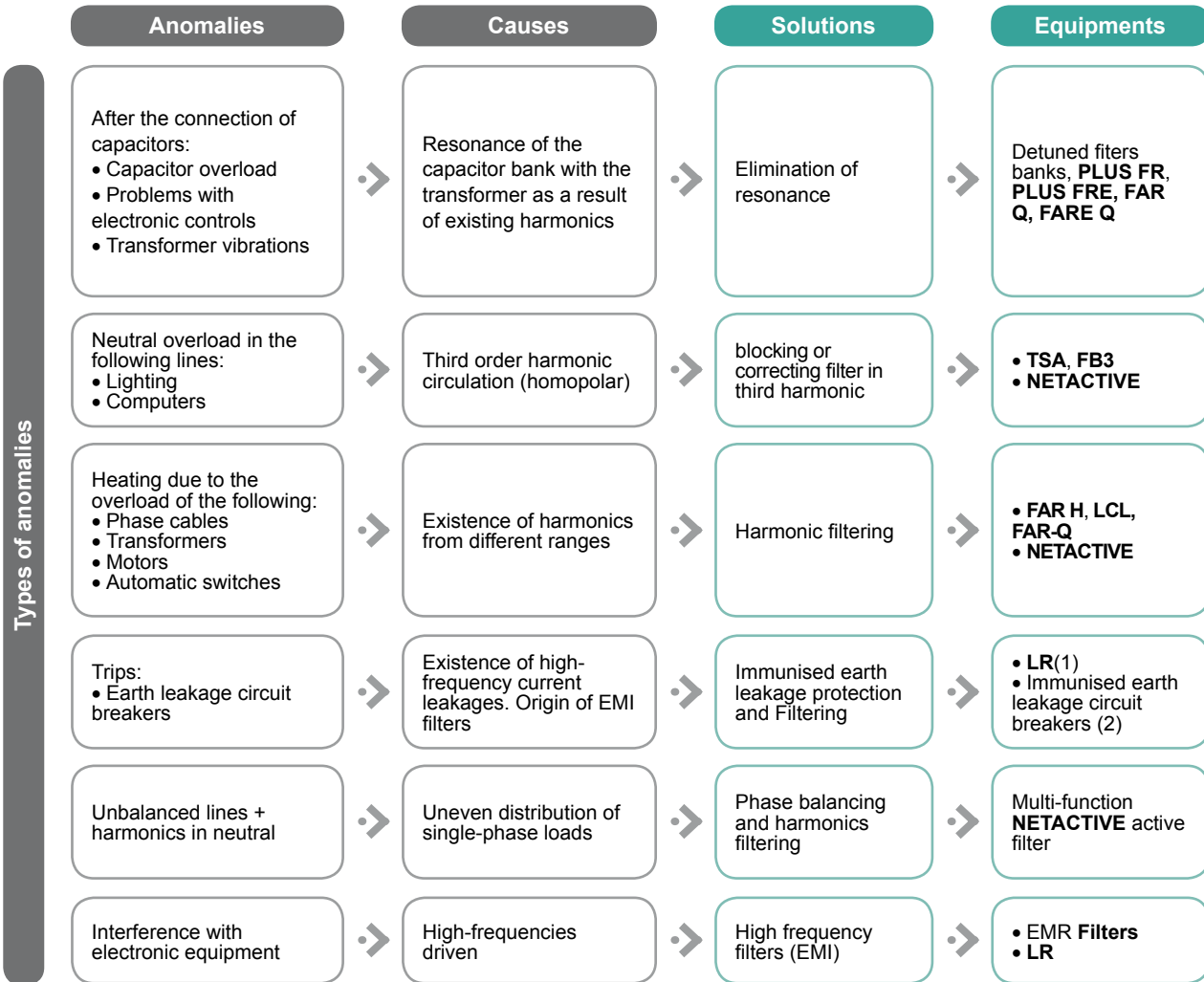

(1) See catalogue, P.7 / (2) See catalogue, P.1

Description of the anomalies and their causes

► Capacitor bank resonance

The connection of capacitor banks in an installation can lead to the amplification of existing harmonics.

• Amplification is described as the increase in the total harmonic distortion, both in terms of voltage and current. To understand this phenomenon, a standard installation is studied. Therefore, the installation's single-line diagram is modelled in an equivalent electric circuit, with 3 types of receivers:

- Generators of harmonics
- Receivers that do not generate disturbances in the electrical network
- Capacitor banks (harmonic sinks)

► Forecasted parallel resonance

The resonance in the system depends on the following:

- Harmonic order (n) at which the system resonates.

It is calculated with the following formula:

$$n = \sqrt{\frac{S_{cc}}{Q}}$$

S_{cc} : Transformer's short-circuit power
 Q : Power factor of the capacitor bank

- Existence of harmonics at the resonance frequency
- Situation of other network loads (active power consumed)

RESONANCE EXAMPLE

The two following graphs compare the installation's values, with a high rate of harmonics, showing the situation before and after the connection of the capacitor bank.

As a consequence, the values of THD(I) and THD(U) are increased.

Measurement without a capacitor bank:

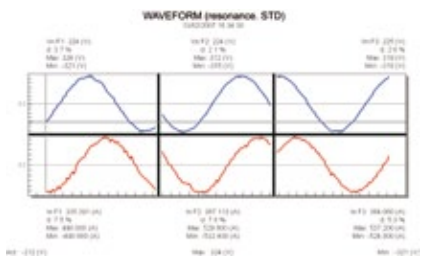

Measurement with a capacitor bank:

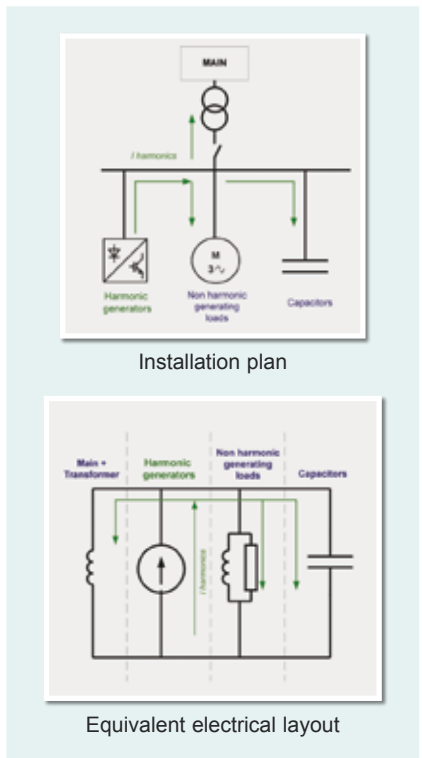
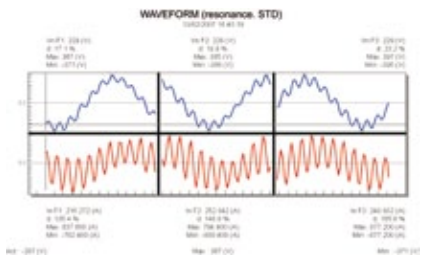

For more information, see PLUS FR / PLUS FRE

Amplification

A circuit will be analysed after it has been modelled. The most unfavourable case is considered to simplify the example,

i.e., when there is only a mains transformer, capacitor bank and harmonic generation load in the installation.

The resulting circuit corresponds to a reactance (transformer + network) and capacitor (bank) in parallel with the current sources (harmonics).

The parallel resonance is produced under these conditions and, as a result, the amplification of harmonics.

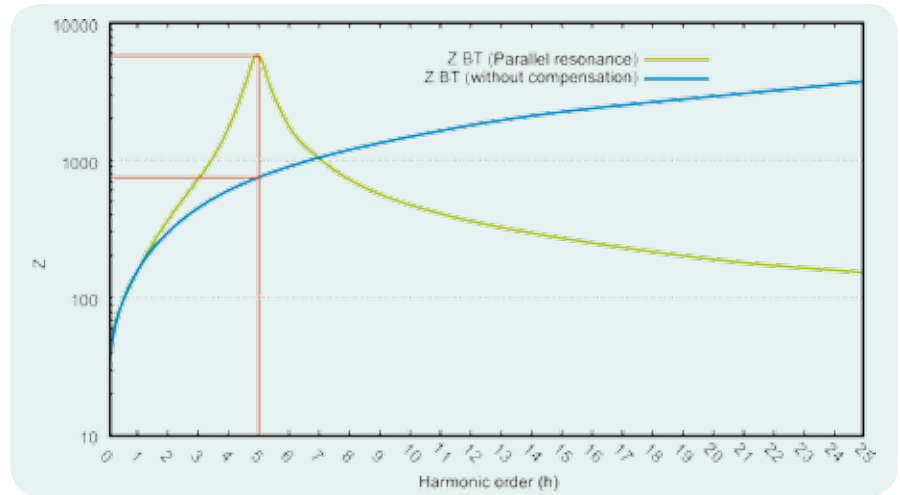
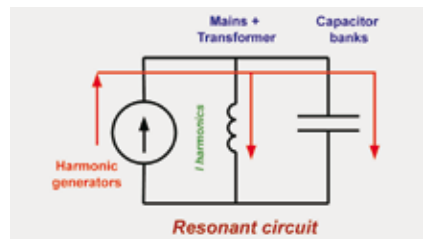

Resonance curve

Transformer + capacitor bank + injection of 5th and 7th order harmonic

➔ Increase of $Z_s \rightarrow$ Therefore, increase of U_s
 $U_s = I_s \cdot Z_s$

➔ As a consequence, increase of THD(U)
 $THD(U)\% = \frac{\sqrt{\sum_{n=2}^{40} U_n^2}}{U_1} \cdot 100$

⚠

- Distortion of the voltage and current signal
- Capacitor overload Vibrations in machines Problems with electronic controls
- Protection trips, deterioration of the insulation

► Causes

○ Parallel resonance: increase of the impedance of the transformer circuit + network and bank with a determined frequency value

► Consequences

○ Increase of harmonic voltages and, therefore, of the THD(U)

○ High currents in each of the branches of L and C

Protection trips, deterioration of the insulation, etc. The amplification is observed in the system impedance representation curve, depending on the frequency.

The curve shows a high impedance value when compared to the initial value of the network with no capacitors. The following sequence shows a summary of events, taking the attached graph as an example:

Conductor overload, automatic machines and switches

In installations with high total harmonic distortion, the real value of the current and voltage can

increase greatly when compared to the fundamental values, generating overloads and, as a consequence, overheating.

To understand this anomaly, the RMS value is defined, i.e., the root mean square of a signal, taking into account the fundamental component and existing harmonic components.

$$I_{rms} = \sqrt{(I_1^2 + I_3^2 + \dots + I_n^2)}$$

$$U_{rms} = \sqrt{(U_1^2 + U_3^2 + \dots + U_n^2)}$$

Therefore, a clear consequence of the increase in the RMS value of the current is the increase in loss levels, which are classified in two types:

- Losses in copper caused by the Joule effect
- Magnetic losses caused by hysteresis and the Foucauld effect

sis and the Foucauld effect

The example shows how the value of the RMS current is 631 A, while the value of the fundamental component is 536 A. This represents an 18% increase when compared to the fundamental value. In addition, there is an increase in the heating of magnetic plates, depending on the frequency of existing harmonics.

Phase unbalance

The distribution of single-phase loads in three-phase lines always leads to unbalances in phase currents. The importance of unbalanced currents will depend on the distribution of loads.

The unbalance existing in a three-phase system leads to the generation of a resulting current that is transmitted through the neutral conductor.

If we add the existence of a third order harmonic component to the unbalanced current value, the RMS value transmitted through the neutral will be the sum of both values.

$$I_{rms} = \sqrt{(I_d^2 + I_3^2)}$$

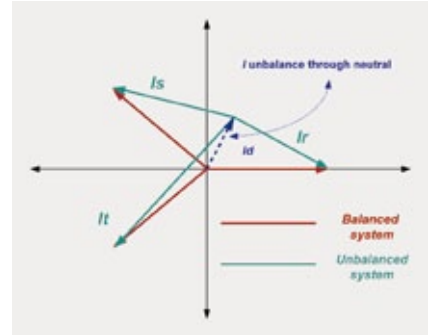

See phase balancing equipment

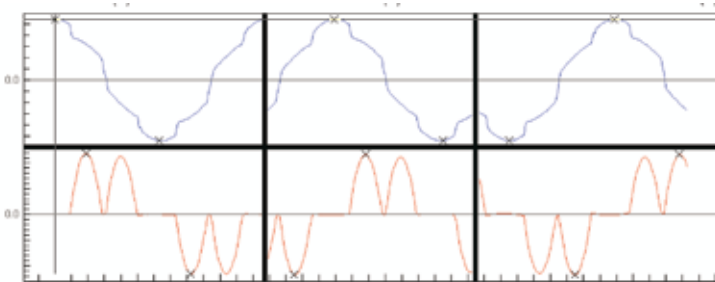

Corriente fase 1		
Imax (A) 631	THD (%) 53.0	
Fundamental (A) 536	Distorsión (%) 8.1	
Armónico	Amplitud (%)	Amplitud (A)
2 (+)	1.142	
3 (-)	1.696	
4 (+)	1.715	
5 (-)	55.083	
6 (+)	1.398	
7 (+)	26.649	

See harmonic filtering

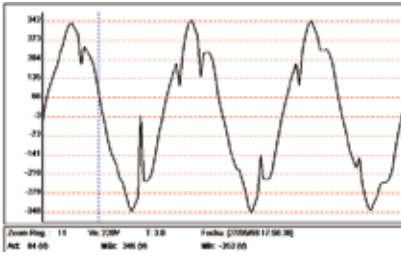

See filters for HF

Neutral overload: third order harmonic (homopolar currents)

Third order harmonics are added to the neutral, producing the so-called homopolar components.

These components are added to the unbalance in consumption and can lead to overload problems in the neutral conductor.

The loads that produce harmonics in multiples of 3 are:

- Electronic equipment (computers)
- Single-phase rectifiers, loads working with the electric arc, such as discharge lamps, etc.

Said loads, usually single-phase, are connected between the phase and neutral. Therefore, the circuit is closed for the return of the third order harmonic through the neutral, with no distribution of loads between phases, which helps reduce the value, since the currents of the third order harmonic are added to all phases.

Therefore, the neutral conductors transmit the sum of third order harmonics of the three phases from the points where the loads are found to the general transformer.

Take into account that the loads from discharge lamps can generate 30% or more of its current in the third order harmonic. So, the value of the current in the neutral can reach values that are almost that of the phase current and it can even exceed them.

Interference on electronic equipment. High frequencies (10 kHz to 30 MHz)

High-frequency alterations are usually caused by electronic converters used in speed variators, both AC and DC, and in uninterruptible power supply systems (UPS).

The EMI high-frequency alterations are caused by sudden voltage and current peaks caused by transistor switching operations or IGBT.

There are two types of HF alterations:

▶ Earth leakage mode alterations

The high-frequency altering currents are transmitted both ways through phase and/or neutral conductors.

▶ Common mode alterations

Altering currents are transmitted one way through the phases and neutral and they return through the protection conductor. These signals can lead to the faulty operation of the PLC, computers and control equipment used with low level signals, causing earth leakage trips.

See units to discharge the neutral

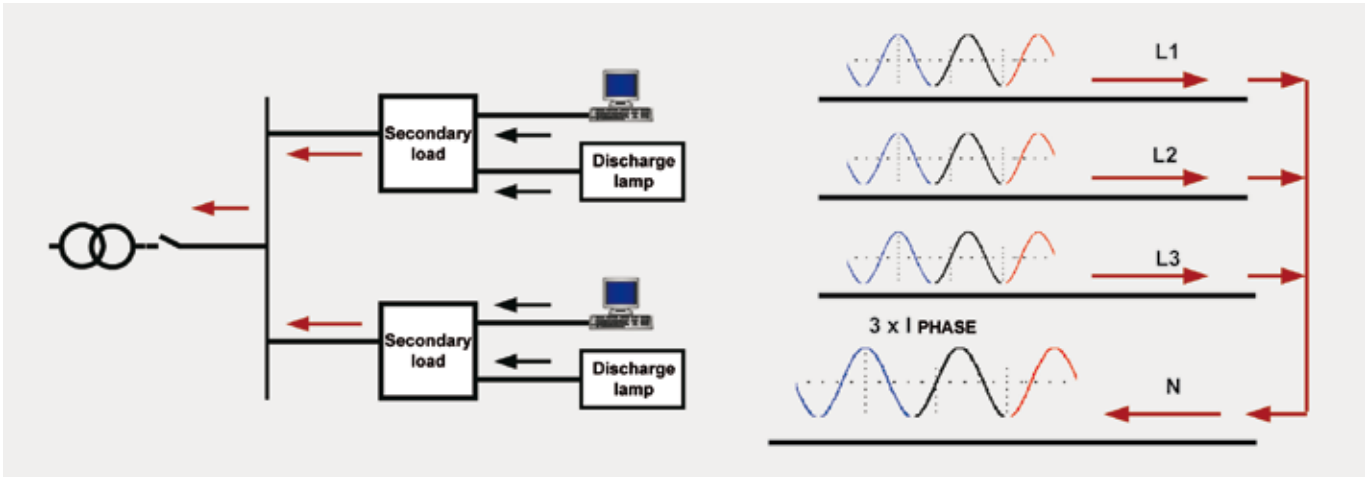

B Alteration filtering solutions

Different types of units are required to neutralise the different types of anomalies detected.

There are five categories that classify the unit in accordance with the objective desired:

- B.1: Power factor correction in networks with harmonic currents
- B.2: Harmonic filtering
- B.3: Neutral discharges
- B.4: HF Filtering
- Phase unbalance (see NETACTIVE MULTIFUNCTION)

Power factor correction in networks with harmonic currents

The Power factor correction in networks with a high content of harmonics can be carried out under two different objectives, as shown on the following diagram:

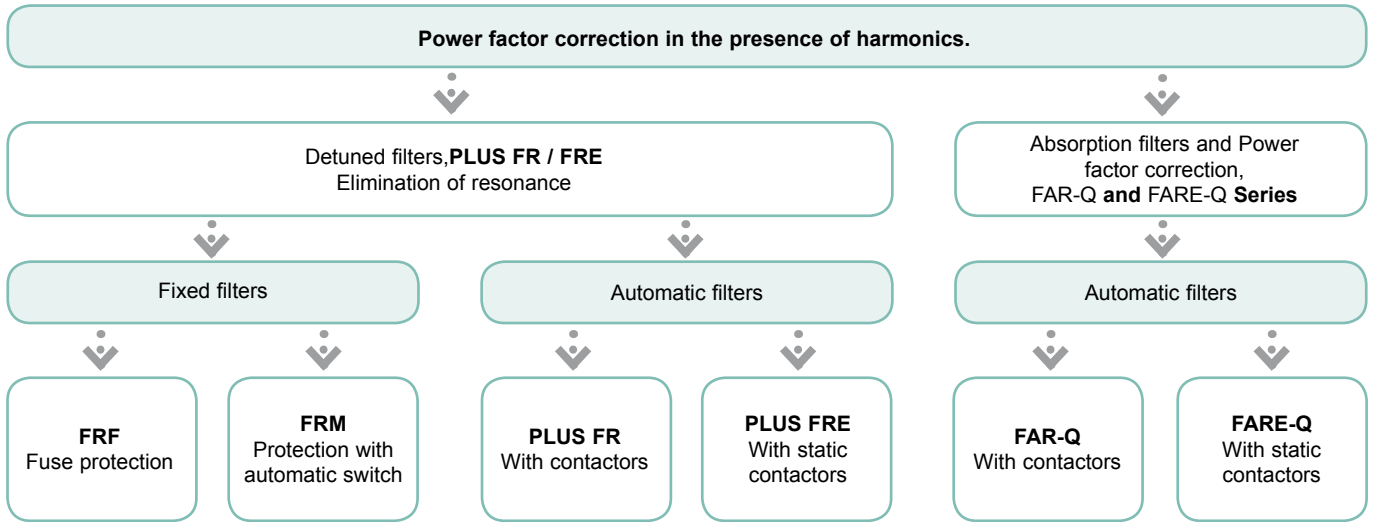

C Installation locations of filtering equipment

There are three locations in an installation where alteration elimination units can be installed. These are:

In the terminals of the harmonic generation loads

This is the best location since it eliminates alterations from the place where they are produced, avoiding their transmission throughout the installation distribution lines.

Example: Medium or high-power frequency variator (LCL Filter).

In secondary panels

In the case when there are different small power loads connected to the secondary distribution panels. Their elimination allows the discharge of the lines connected to the mains panel.

Example: Computer lines or discharge lamps, in general (TSA or FB3 blocking system).

On the Low Voltage panel

The installation on the mains panel of a filtering equipment after the elimination or attenuation of the loads from secondary panels allows the elimination of the remaining residual alterations.

The correct condition of the electrical signal can be guaranteed at the connection point with the supply Company.

Example: General filtering of the LV mains panel of a Hotel, having previously discharged the neutral lines (NETACTIVE active filters)

Selecting the place of installation

Take the following into account before selecting the correct place to install the unit:

- ▶ Type of incident in the installation and, therefore, the type of filter selected
- ▶ Configuration of the installation:
 - Existence of capacitor banks
 - Existence of major disturbance loads
 - Power and location of lighting and computer lines
 - Existence of other loads, such as induction furnaces, welds

	SOLUTION	LV MAINS PANELS	LV SECONDARY PANELS	INDIVIDUAL
FR/FRE Detuned filters	Power factor correction	●	●	
Active Filters Three-phase Single-phase	Compensation of harmonics	●	●	
FAR Regulated Absorption Filters	Harmonic filtering Power factor correction	●	●	
LCL Filters LR Reactances	Harmonic filtering			●
EMI Filters (EMR)	High-frequency filtering			●
Blocking Systems (TSA, FB3)	Discharge of the third order harmonic		●	

Table with the summary of the installation location of filtering equipment

NETACTIVE Active filters

Active filters are units that have been conceived to compensate harmonic currents.

Compensation of harmonics

The compensation is achieved with the counter-phase injection of harmonic currents that are identical to those existing in the installation.

This achieves a signal with practically no harmonic distortion under the filter connection point.

The current is automatically regulated

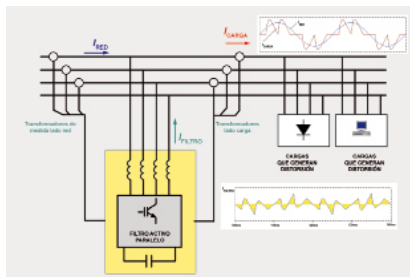

Operation principle

Active filters are based on the following principle:

$$I_{\text{FILTER}} = I_{\text{NETWORK}} - I_{\text{LOAD}}$$

In other words, they detect the difference existing between the desired sine wave (I_{NETWORK}) of the current and the signal deformed by the effect of harmonics (I_{LOAD}). Therefore, the difference existing between both waves is injected (I_{FILTER}).

The following figure shows the wave shapes of currents injected by active filters. It shows the desired wave, the existing deformed wave and the filter current (I_{FILTER}), in the case of a single-phase filter and a three-phase filter.

Single-phase filter

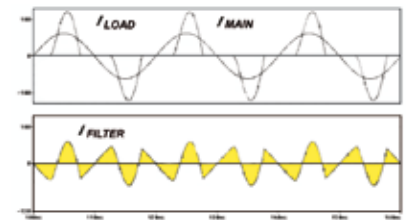

Three-phase filter

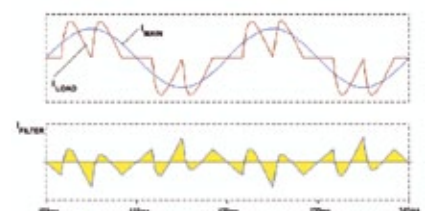

When should an Active Filter be used

The active filter is ideal in any application that has a large variation of loads, a wide spectrum of harmonics that must be compensated and a whole distribution of non-linear loads that are heavily distributed in the form of small network loads, so that it is not possible to use individual passive filters.

The most common applications are:

- Lighting lines
- Computer lines
- Lines with different types of loads (lighting, computers, speed variators)

In other words, the most common application is in office buildings, hospitals, etc.

Range

CIRCUTOR offers a wide range of units in the active filter family, which can adapt to the different types of anomalies existing in installations.

The following diagram shows the different families:

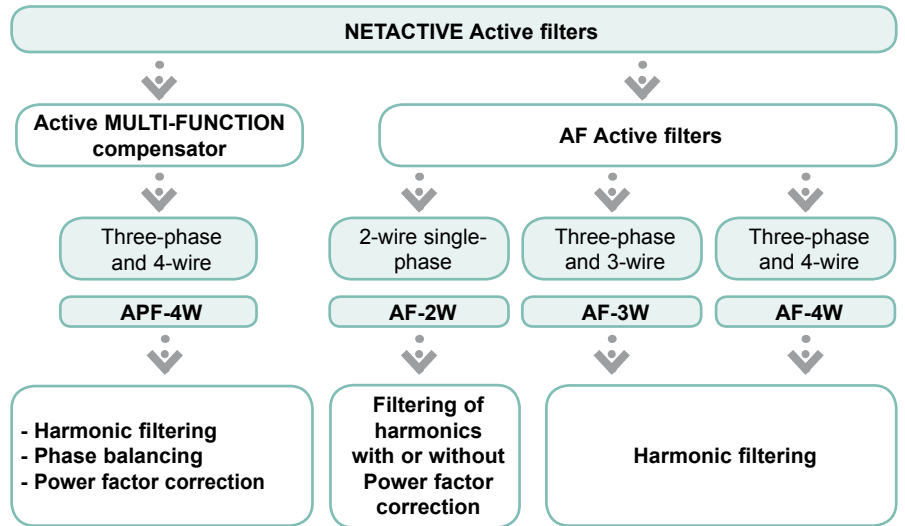

Filtering unit selection guide

The following guidelines provide helpful information when choosing the type of unit, in accordance with its location in the installation, the type of load filtered and the installation's objectives.

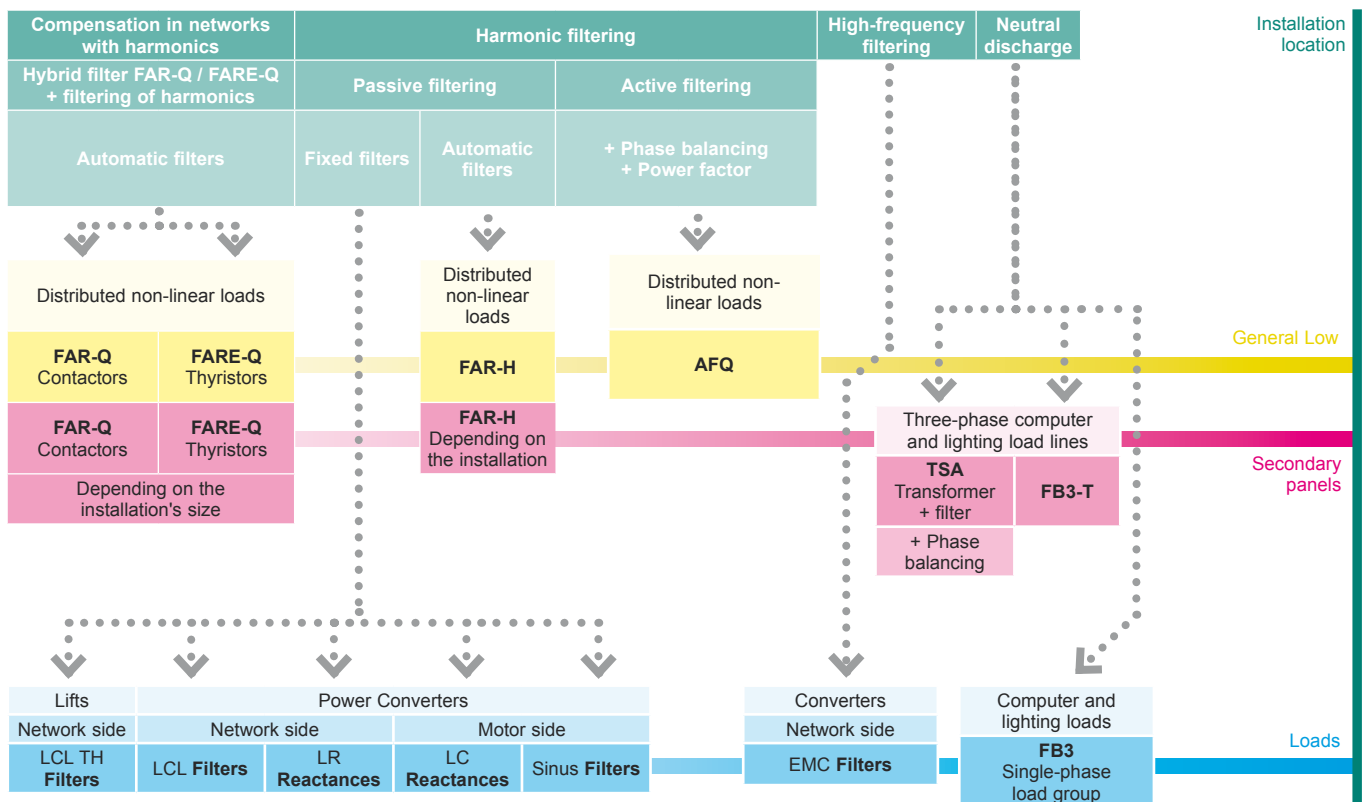

LCL

Harmonic filter for power converters



Description

LCL filters have been specially designed to eliminate the harmonics from the current absorbed by 6-pulse power converters, such as frequency variators for motors, **UPS**, etc.

These are essentially passive filters based on a series-parallel combination of inductances and capacitors, adapted to filter the input of power converters.

Application

- Reduction of the current wave's distortion towards the network and the rest of the installation
- Compliance with the **IEC 61000-3-4, IEC 61000-3-12, IEC 61800-3** and **IEEE-519**
- Energy savings with the reduction of the root mean square current (RMS), thus reducing the kV·A demand.
- Increase of the working life of units above this location with the corresponding reduction of thermal losses generated.
- Limits current transients, preventing damages caused to the converter and overvoltage trips that affect production processes.

Features

Features	
Standard voltage (ph-ph)	400 V a.c. / 480 V a.c. (Others on request)
Frecuency	50 Hz: LCL-35-xx types 60 Hz: LCL-36-xx types
Rated load current (I_c)	See table
Overload	1,5 I_c 1 min more 5 min with I_c (max. operating temperature)
Rated filtering current (I_f) residual THD	See table Aprox. 8 %
Voltage drop at rated current	< 2 %
Build features	
Cabinet material	Treated and painted steel Racks RAL 1013 Door RAL 3005
Degree of protection	IP 20
Locking system	Lock and key
Ventilation	Natural
Mounting	On the floor
Installation	Indoor
Environmental conditions	
Operating temperature	35 °C
Relative humidity	80 %
Standards	
EN 60439, EN 60831, EN 50081-1, EN 50081-2, class A	

LCL

Harmonic filter for power converters



Dimensions

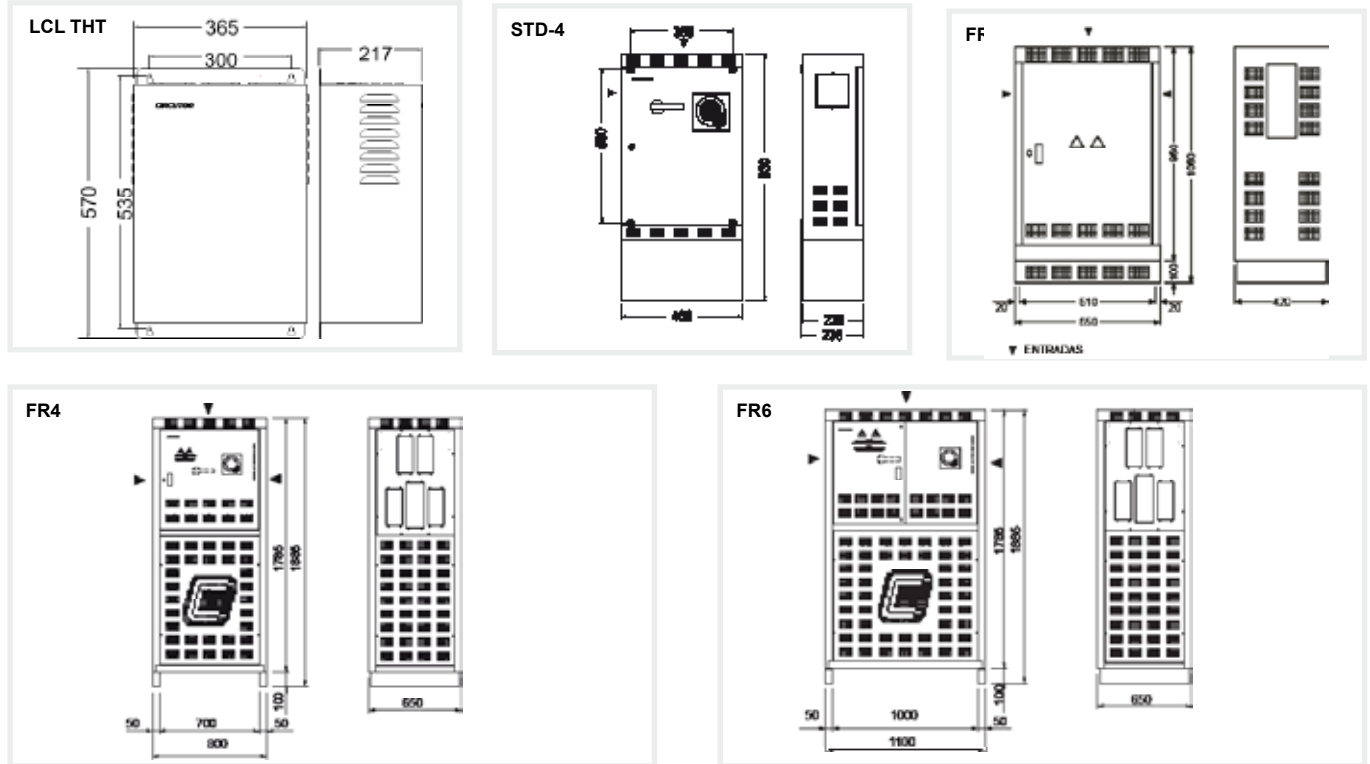

References

LCL 400 - 415 V / 50 Hz

Load current I_c (A)	Q (kvar)	Dimensions (mm) width x height x depth	Cabinet	Type	Code
9	1,76	365 x 570 x 217	LCL TH	LCL 35-9A-400	R73105
12	2,51	365 x 570 x 217	LCL TH	LC L35-12A-400	R73106
16	3,27	365 x 570 x 217	LCL TH	LCL 35-16A-400	R73107
22	4,42	460 x 930 x 230	STD-4	LCL 35-22A-400	R73108
32	6,63	460 x 930 x 230	STD-4	LCL 35-32A-400	R73109
40	8,29	460 x 930 x 230	STD-4	LCL 35-40A-400	R73110
47	9,14	650 x 1060 x 420	FRF	LCL 35-47A-400	R73111
54	10,8	650 x 1060 x 420	FRF	LCL 35-54A-400	R73112
64	13,26	650 x 1060 x 420	FRF	LCL 35-64A-400	R73113
76	14,92	650 x 1060 x 420	FRF	LCL 35-76A-400	R73114
90	18,24	800 x 1900 x 650	FR4	LCL 35-90A-400	R73115
110	23,21	800 x 1900 x 650	FR4	LCL 35-110A-400	R73116
150	29,84	800 x 1900 x 650	FR4	LCL 35-150A-400	R73117
180	36,48	800 x 1900 x 650	FR4	LCL 35-180A-400	R73118
220	46,42	1100 x 1900 x 650	FR6	LCL 35-220A-400	R73119
260	53,06	1100 x 1900 x 650	FR6	LCL 35-260A-400	R73120
320	66,32	1100 x 1900 x 650	FR6	LCL 35-320A-400	R73121
400	79,58	1100 x 1900 x 650	FR6	LCL 35-400A-400	R73122

Other optional voltages, frequencies and currents, on demand.

LCL

Harmonic filter for power converters



References

LCL 460 - 480 V / 60 Hz

Load current I_c (A)	Q (kvar)	Dimensions (mm) width x height x depth	Cabinet	Type	Code
9	2,73	365 x 570 x 217	LCL TH	LCL 36-9A-480	R732050070000
16	4,55	365 x 570 x 217	LCL TH	LCL 36-16A-480	R732070070000
22	6,21	460 x 930 x 230	STD-4	LCL 36-22A-480	R732080070000
32	7,59	460 x 930 x 230	STD-4	LCL 36-32A-480	R732090070000
40	11,38	460 x 930 x 230	STD-4	LCL 36-40A-480	R732100070000
47	15,18	650 x 1060 x 420	FRF	LCL 36-47A-480	R732110070000
54	15,18	650 x 1060 x 420	FRF	LCL 36-54A-480	R732120070000
64	18,97	650 x 1060 x 420	FRF	LCL 36-64A-480	R732130070000
76	22,77	650 x 1060 x 420	FRF	LCL 36-76A-480	R732140070000
90	26,56	800 x 1900 x 650	FR4	LCL 36-90A-480	R732150070000
110	30,36	800 x 1900 x 650	FR4	LCL 36-110A-480	R732160070000
150	45,53	800 x 1900 x 650	FR4	LCL 36-150A-480	R732170070000
180	53,12	800 x 1900 x 650	FR4	LCL 36-180A-480	R732180070000
220	60,71	1100 x 1900 x 650	FR6	LCL 36-220A-480	R732190070000
260	68,3	1100 x 1900 x 650	FR6	LCL 36-260A-480	R732200070000
320	91,07	1100 x 1900 x 650	FR6	LCL 36-320A-480	R732210070000
400	121,42	1100 x 1900 x 650	FR6	LCL 36-400A-480	R732220070000

Connections

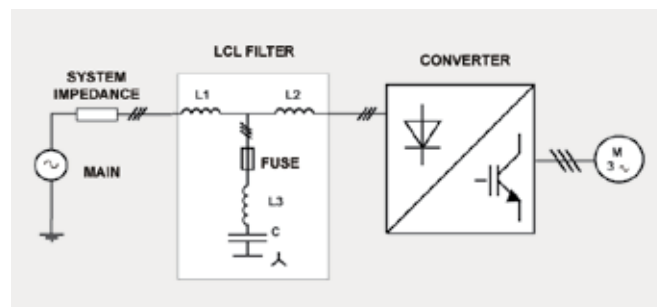

LCL-TH

Harmonic filter for elevators



Description

The **LCL-TH** filter is an **LCL** filter that is regulated through static switching operations (thyristors) and which has been specially designed to compensate harmonics in 6-pulse power converters that work with fluctuating loads and require an instantaneous compensation, for example, lifts, cranes, etc.

Application

Reduction of the current wave's distortion towards the network and the rest of the installation.

Compliance with the **EN 12015, IEC 61000-3-4 and IEC 61000-3-12**

Energy savings with the reduction of the root mean square current (RMS), thus reducing the kV·A demand.

Increase of the working life of units above this location with the corresponding reduction of thermal losses generated.

Limits current transients, preventing damages caused to the converter and overvoltage trips that affect production processes.

Features

Features	
Standard voltage (ph-ph)	400 V a.c. / 480 V a.c. (Others on request)
Frequency	50 Hz: LCL-35-xx types 60 Hz: LCL-36-xx types
Rated load current (I_c)	See table
Overload	1,5 I_c 1 min more 5 min with I_c (max. operating temperature)
Rated filtering current (I_f)	See table
residual THD	Aprox. 8 %
Voltage drop at rated current	< 2 %
Build features	
Cabinet material	Treated and painted steel Racks RAL 1013 Door RAL 3005
Degree of protection	IP 20
Locking system	Lock and key
Ventilation	Natural
Mounting	On the floor
Installation	Indoor
Environmental conditions	
Operating temperature	35 °C
Relative humidity	80 %
Standars	
EN 60439, EN 60831, EN 50081-1, EN 50081-2, clase A	

LCL-TH

Harmonic filter for elevators

Dimensions

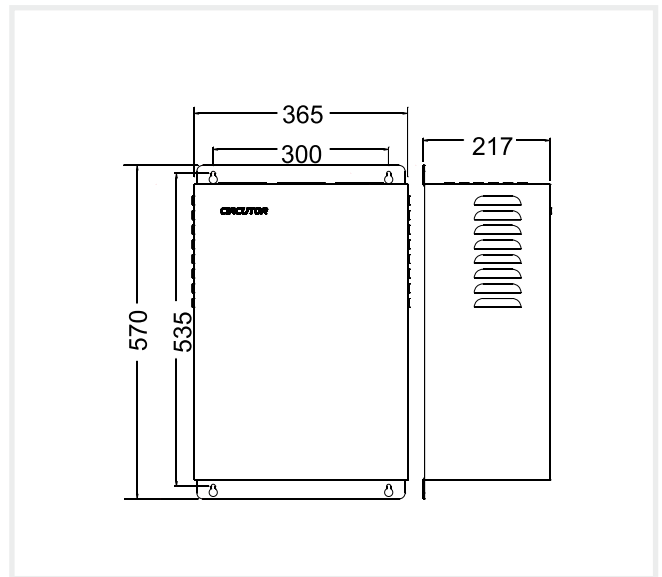

References

LCL-TH 400 - 415 V / 50 Hz

Load current I_c (A)	Q (kvar)	Dimensions (mm) width x height x depth	Type	Code
7	1,76	365 x 570 x 217	LCL-TH35-7A-400	R7K104
9	1,51	365 x 570 x 217	LCL-TH35-9A-400	R7K105
12	2,51	365 x 570 x 217	LCL-TH35-12A-400	R7K106
16	3,27	565 x 700 x 245	LCL-TH35-16A-400	R7K107
22	4,42	565 x 700 x 245	LCL-TH35-22A-400	R7K108

Connections

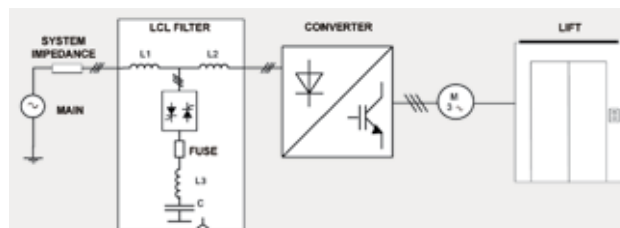

SINUS

Filter for PWM

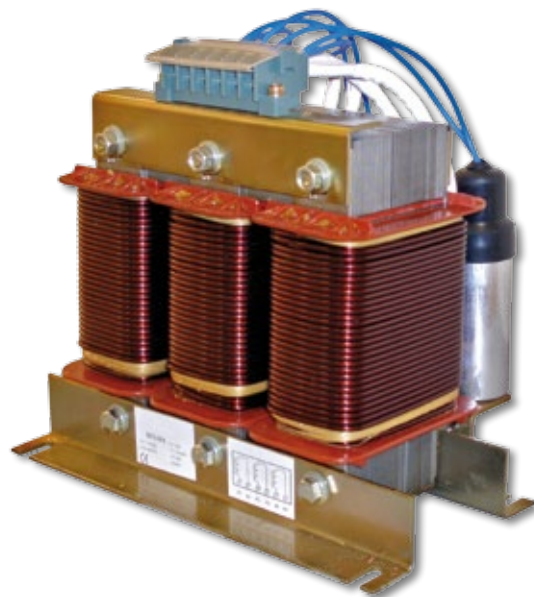

Description

Sinus filters have been specially designed to improve the wave form and avoid overvoltages in the motors.

These filters are installed in inverters with PWM output, between the converter and the motor. Switching IGBT (isolated gate bipolar transistor) to high frequency causes an output voltage with peaks that can reach 1300 V (or more) in terminals and coils of the motor.

These constant voltage values age the motor and decrease the performance of the coils, also wearing and pitting bearings, causing overheating and unnecessary noises and the transmission of interferences through cables. This effect becomes more obvious the greater the distance between the converter and the motor.

Application

It improves the quality of the output wave of the PWM (pulse width modulator), especially in long lines connected to the motor.

Reduction of overvoltage peaks caused by PWM and, therefore, a lower wear of motor insulation systems and bearings.

Attenuation of the interference emissions radiated by the conductors between the modulator and motor.

Features

Features	
Nominal voltage	380 - 400 V a.c.
Frequency	50 / 60 Hz
Nominal current	4 ... 400 A
Standard voltage drop	4 %
Maximum permanent overload	$1.17 I_n$
Maximum transient overload	$2 I_n$
Construction	Copper conductor. Aluminium band
Switching	2...10 kHz
Insulation level	2 kV
Connection	Aluminium plate. Terminals
Degree of protection	IP 00 / IP 20
Installation	Indoor
* Other voltages, nominal currents or switching frequency, on demand. Single-phase filters, on demand	

Connections

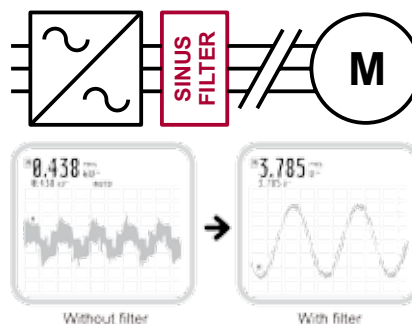

SINUS

Filter for PWM

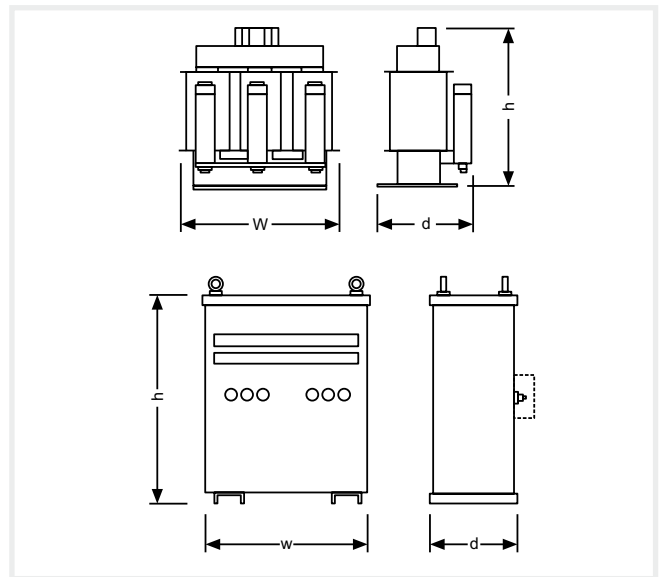
Dimensions**References**

SINUS filter, no casing (IP 00), 400 V

I_n (A)	Switching frequency (kHz)	Dimensions (mm) width x height x depth	Type	Code
4	10	150 x 150 x 110	SINUS-4-40-00	R7S000
6	10	191 x 180 x 120	SINUS-6-40-00	R7S001
10	10	191 x 180 x 120	SINUS-10-40-00	R7S002
16	10	240 x 237 x 165	SINUS-16-40-00	R7S003
25	10	244 x 301 x 248	SINUS-25-40-00	R7S004
48	10	235 x 324 x 293	SINUS-48-40-00	R7S005
80	10	290 x 422 x 360	SINUS-80-40-00	R7S006
115	10	330 x 421 x 360	SINUS-115-40-00	R7S007
150	10	390 x 503 x 360	SINUS-155-40-00	R7S008
180	2	310 x 525 x 370	SINUS-180-40-00	R7S009
270	2	415 x 557 x 360	SINUS-270-40-00	R7S00A
400	2	580 x 703 x 450	SINUS-400-40-00	R7S00B

SINUS filter, with casing (IP 20), 400 V

I_n (A)	Switching frequency (kHz)	Dimensions (mm)	Type	Code
4	10	285 x 280 x 175	SINUS-4-40-20	R7S010
6	10	285 x 280 x 175	SINUS-6-40-20	R7S011
10	10	285 x 280 x 175	SINUS-10-40-20	R7S012
16	10	475 x 460 x 302	SINUS-16-40-20	R7S013
25	10	475 x 460 x 302	SINUS-25-40-20	R7S014
48	10	475 x 460 x 302	SINUS-48-40-20	R7S015
80	10	740 x 696 x 447	SINUS-80-40-20	R7S016
115	10	740 x 696 x 447	SINUS-115-40-20	R7S017
150	10	740 x 696 x 447	SINUS-155-40-20	R7S018
180	2	740 x 696 x 447	SINUS-180-40-20	R7S019
270	2	740 x 696 x 447	SINUS-270-40-20	R7S01A
400	2	845 x 795 x 555	SINUS-400-40-20	R7S01B

AFQ

Multifunction Parallel Active Filter



Description

AFQ multifunction parallel active filters are the most complete solution to solve those quality problems caused, in either industrial or commercial facilities, not only by harmonics but also for current unbalance, and, even, reactive power consumption (mostly leading PF).

The available functions in all models are following ones:

- Reduction of harmonics currents up to the 50th order (2500 Hz). User-selection of harmonic frequencies to be filtered for a higher efficacy.
- Correction of the unbalanced current consumption in each phase of the electric power system.
- Reactive power compensation. Either lagging currents (inductive) or leading currents (capacitive).
- These filters offer a configurable function priority for an optimal use of the filter capabilities according to the installation needs.

In case of higher filtering requirements, up to a maximum of 8 filters may be connected in parallel (all units must be of same rating).

Application

Ideal solution for installations with a large quantity of single and three-phase loads that generate harmonics, such as computers, UPS, lights, lifting units, air-conditioning systems with speed variators, etc.

Features

Electrical characteristics	
Rated operating voltage	400 V _{a.c.} ± 15%
Frequency	50 Hz / 60 Hz ± 10%
Connection system	3 phase + neutral (4 wire)
Filter specifications	
Current harmonics range	2nd to 50th harmonic
Specified harmonic selection	2nd to 25th harmonic
Current balancing function	Available
Reactive compensation function	Available
Controller technology	DSP (digital signal processor)
Transient response time	< 1 ms
Current limitation	Protection against over current by limitation to the filter rating value
Graphic display	LCD touch screen
Display functions	
Control capabilities	Filter On/Off, reset of alarms, and filter status description.
Setup functions	Selection of individual harmonics to filter, current balancing option, reactive compensation function, current transformer ratio, minimum running current, control algorithm, and number of AFQ units in parallel.
Electrical parameters monitoring	Voltages and currents measurements. Active, reactive and apparent power, and power factor measurements. Current harmonics and harmonic spectrum graph.
Standards	
Reference Harmonic Standard	IEC 61000-3-4, IEEE 519-1992
Reference Design Standard	IEC 60146
Safety Standard	EN 50178
Electromagnetic Compatibility	EN 55011, IEC EN 50081-2, IEC 61000-4-2, IEC 61000-4-3, IEC 61000-4-4, IEC 61000-4-5, IEC 61000-6, IEC 61000-6-2
Environmental conditions	
Operating temperature	0 ... +50 °C
Humidity	0 ... 90 % (without condensation)
Maximum altitude	2000 m
Enclosure characteristics	
Mounting	Self-standing cubicle
External color	Light grey RAL 7035
Protection degree	IP 21
Installation	Indoor use
Cable entry	Bottom

AFQ

Multifunction Parallel Active Filter



Dimensions and weight

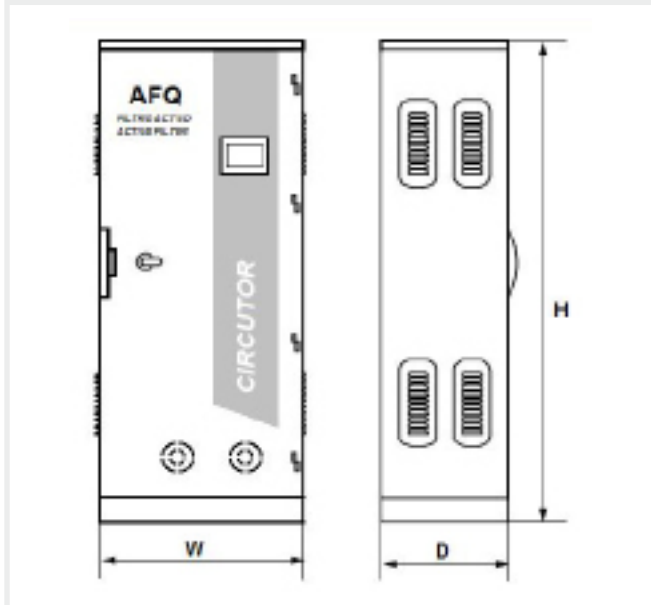

Model	Dimensions (W x H x D)	Weight (kg)
AFQ-4W5-25A-400	655 x 800 x 450	135
AFQ-4W5-50A-400	655 x 1350 x 450	212
AFQ-4W5-100A-400	665 x 1800 x 450	272
AFQ-4W5-150A-400	1200 x 1900 x 750	480
AFQ-4W5-200A-400	1200 x 1900 x 750	490

Connection

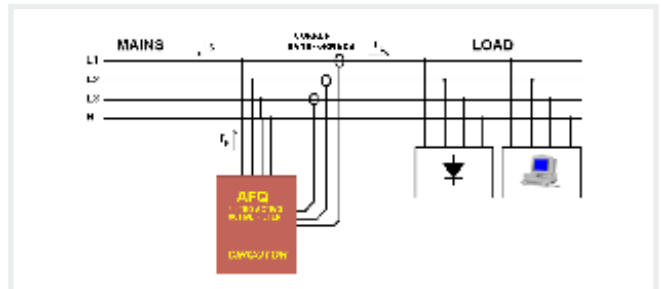

References

ACTIVE MULTI-FUNCTION FILTER (4 WIRES), AFQ SERIES, Harmonic filtering, Phase balancing and Power factor regulation



Harmonic phase current	Harmonic neutral currents	Harmonic peak current	Type	Code
25 A _{RMS}	75 A _{RMS}	50 A _{RMS}	AFQ-4W5-25A-400	R7H602
50 A _{RMS}	150 A _{RMS}	100 A _{RMS}	AFQ-4W5-50A-400	R7H604
100 A _{RMS}	300 A _{RMS}	200 A _{RMS}	AFQ-4W5-100A-400	R7H605
150 A _{RMS}	450 A _{RMS}	300 A _{RMS}	AFQ-4W5-150A-400	R7H606
200 A _{RMS}	600 A _{RMS}	400 A _{RMS}	AFQ-4W5-200A-400	R7H607

FB3

Third harmonic blocking filter



Description

FB3 filters block 3rd order harmonics and have been designed to reduce these harmonics in installations with distorting single-phase loads.

Application

For single-phase loads, such as PCs, TFT screens, projectors, etc.

Dimensions

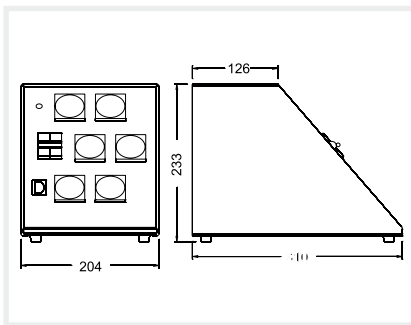

Features

Features	
Voltage	110 ... 240 V a.c.
Frequency	50 Hz (60 Hz, on demand)
Environmental conditions	
Operating temperature	35 °C
Relative humidity	80% non-condensing
Degree of protection	IP 21

Connections

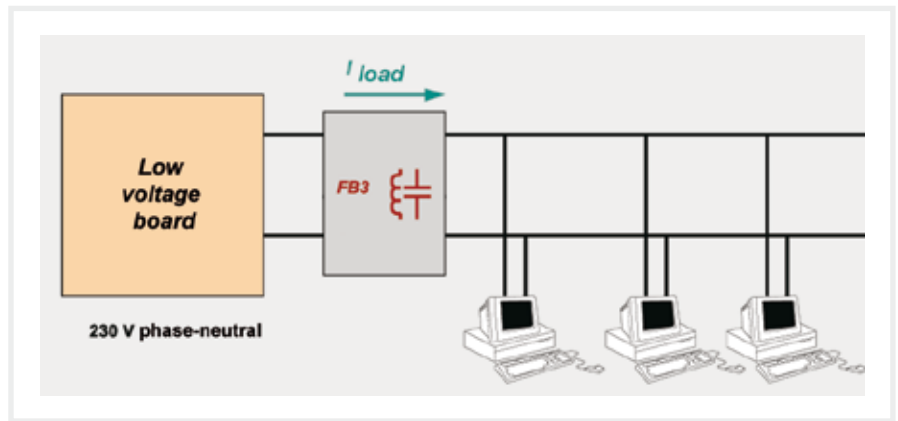

References

FB3 for single-phase network

/ Maximum neutral (A)	Frequency (Hz)	System	Weight (kg)	Dimensions (mm) width x height x depth	Type	Code
6	50 Hz	Single-phase	8	204 x 310 x 233	FB3-5-06	R78101

FB3T

Third harmonic blocking filter



Description

FB3T filters block harmonics in multiples of 3 and have been designed to reduce third order harmonic currents.

Application

Installations with lights, dimmers, computers or any other type of single-phase loads connected between the phase and the neutral.

Dimensions

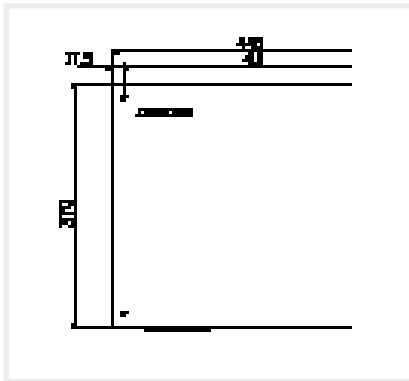

Features

Features	
Voltage: Phase - Neutral	Up to 750 V
Frequency	*FB3T-5-xx , 50Hz *FB3T-6-xx , 60Hz
Standard nominal currents I_R	6, 10, 16, 25, 32, 50, 63, 100 A
Maximum transient current	$1.5 I_R$ (1 minute every 10 minutes)
Terminals (insert in series with neutral conductor)	N1 – N2
Environmental conditions	
Operating temperature	-10° ... +50 °C
Maximum relative humidity (non-condensing)	95 %
IP Degree of protection	IP 00 IP 21 (acc. EN 60.529)

Connections

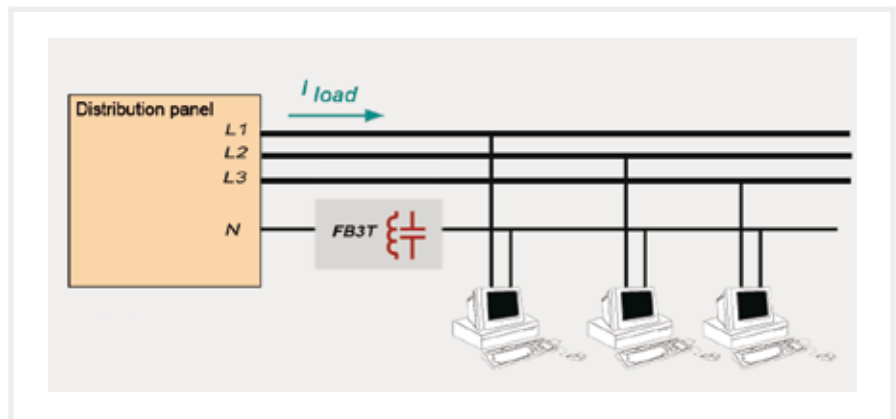

References

FB3T - for three-phase network (50 Hz)

Without box (IP 00)

Dimensions A x B x C (mm)	Type	Code
300 x 200 x 200	FB3T-5-06-00	R78131
300 x 200 x 200	FB3T-5-10-00	R78132
300 x 200 x 200	FB3T-5-16-00	R78133
370 x 280 x 300	FB3T-5-25-00	R78134
370 x 280 x 300	FB3T-5-32-00	R78135
370 x 280 x 300	FB3T-5-50-00	R78136
370 x 420 x 370	FB3T-5-63-00	R78137
370 x 420 x 370	FB3T-5-100-00	R78138

With box (IP 21)

Dimensions A x B x C (mm)	Type	Code
300 x 200 x 200	FB3T-5-06-21	R78121
300 x 200 x 200	FB3T-5-10-21	R78122
300 x 200 x 200	FB3T-5-16-21	R78123
370 x 280 x 300	FB3T-5-25-21	R78124
370 x 280 x 300	FB3T-5-32-21	R78125
370 x 280 x 300	FB3T-5-50-21	R78126
370 x 420 x 370	FB3T-5-63-21	R78127
370 x 420 x 370	FB3T-5-100-21	R78128

TSA

Insulation transformer with harmonic filtering



Description

TSA is a third harmonic filter based on a insulation transformer with a star- triangle connection (Δ -Y), which eliminates third order harmonics and has a passive 5th order harmonic filter in the secondary panel.

Therefore, this configuration eliminates third order harmonics from the neutral conductor and reduces 5th order harmonics.

Application

Lines with the distribution of distorting single-phase loads, such as computers, discharge lamps, etc.

Reduction of neutral overloads with the circulation of third order harmonics.

Decrease in the installation's losses.

Features

Features	
Transformer - divider	
Primary connection	Triangle
Secondary connection	Star
Voltage	3x400/230 V a.c.
Frequency	50 Hz
Conductor	Copper
Filter	Anti-parasitic
Protection switching operations	Circuit breaker II
Power protection	Circuit breaker III + Earth Leakage
Operating temperature	-10...+ 40 °C
Cabinet	IP 42, Epoxy paint

Connections

Three-phase installation with distribution of single-phase loads

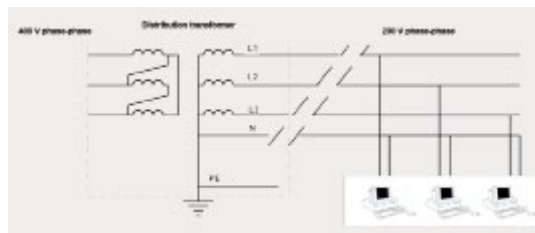

Three-phase installation with TSA and distribution of single-phase loads

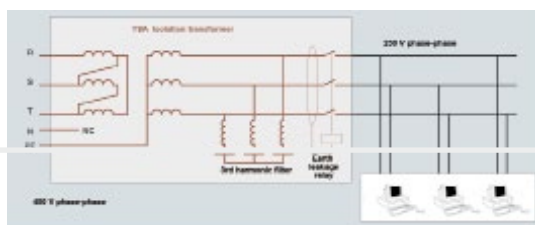

TSA

Insulation transformer with harmonic filtering

Dimensions

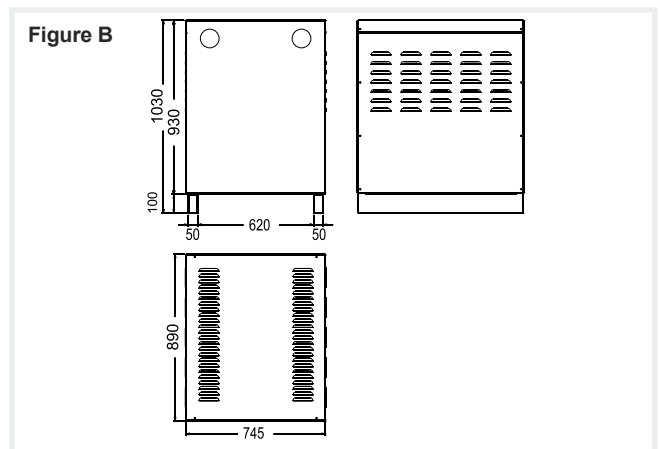
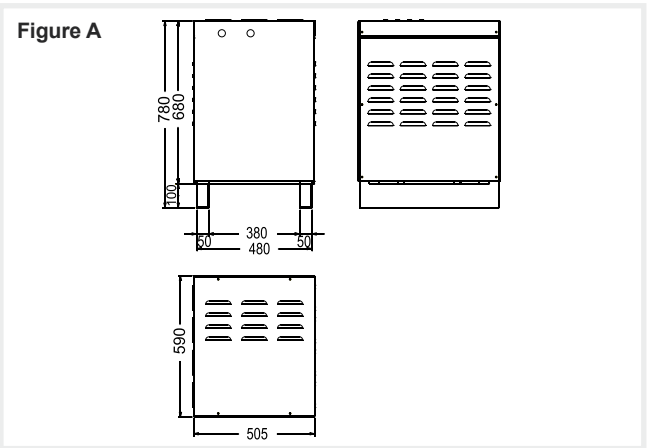

References

kVA	Voltages	Weight (kg)	Dimensions (mm) width x height x depth	Figure	Type	Code
10	3 x 400 / 230 V	125	505 x 780 x 590	A	TSA - 10	R75101
15	3 x 400 / 230 V	160	505 x 780 x 590	A	TSA - 15	R75102
20	3 x 400 / 230 V	185	505 x 780 x 590	A	TSA - 20	R75103
30	3 x 400 / 230 V	265	745 x 1030 x 890	B	TSA - 30	R75104
40	3 x 400 / 230 V	325	745 x 1030 x 890	B	TSA - 40	R75105
50	3 x 400 / 230 V	350	745 x 1030 x 890	B	TSA - 50	R75106
80	3 x 400 / 230 V	420	745 x 1030 x 890	B	TSA - 80	R75107
100	3 x 400 / 230 V	460	745 x 1030 x 890	B	TSA - 100	R75108

EMR

High-frequency filter



Description

The **EMR** filters have been designed to reduce the high-frequency electromagnetic interferences generated by power converters as a consequence of semi-conductor switching operations.

Application

- Compulsory compliance with the electromagnetic compatibility directives for all units with electrical or electronic components.
- Avoid the propagation of electromagnetic distortions transmitted to sensitive receivers.

Features

Features	Single-phase	Three-phase
Maximum supply voltage	250 V a.c.	440 V a.c.
Frequency	50 ... 60 Hz	
Dielectric rigidity	2.5 kV	
Admissible current	see tables	
Overload conditions	1.5 I _n 1 min every 20 min at 40 °C	
Common mode attenuation	50 ... 60 dB	
Range of frequencies	150 kHz ... 30 MHz	
Environmental conditions		
Operating temperature	35 °C	
Relative humidity	80 % non-condensing	

Dimensions

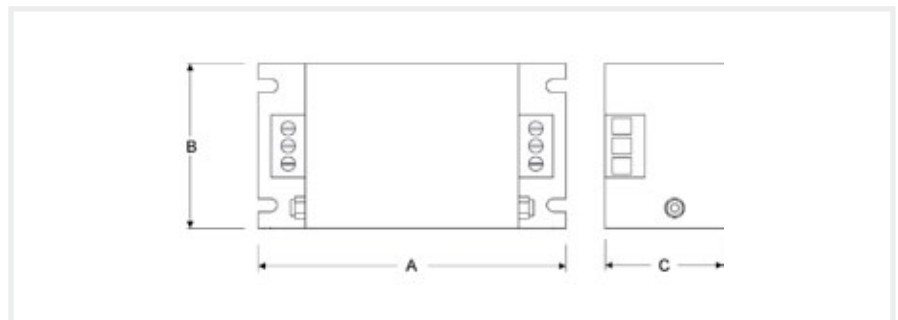

EMR

High-frequency filter

**References**

Single-phase, Power supply up to 250 V, 50 or 60 Hz

I_n (A)	Weight (kg)	$I_{leakage}$ (mA)		Losses (W)	Dimensions (mm) A x B x C	Type	Code
		Min.	Max.				
10	1,6	-	3,2	4	150 x 55 x 45	EMR-10-M250	R71101
15	1,6	-	3,2	7	150 x 55 x 45	EMR-15-M250	R71102
25	2,2	-	3,2	10	170 x 80 x 55	EMR-25-M250	R71103
35	2,4	-	3,2	15	170 x 80 x 55	EMR-35-M250	R71104

Three-phase, Power supply up to 480 V, 50 or 60 Hz

EMR, without neutral

I_n (A)	Weight (kg)	$I_{leakage}$ (mA)		Losses (W)	Terminals and screws	Dimensions (mm) A x B x C	Type	Code
		Min.	Max.					
6	1,6	0,5	27	8	B: 6 mm ²	250 x 110 x 60	EMR-06-T440	R71201
12	1,6	0,5	27	10	B: 6 mm ²	250 x 110 x 60	EMR-12-T440	R71202
20	2,2	0,5	27	15	B: 10 mm ²	270 x 140 x 60	EMR-20-T440	R71203
40	2,4	0,5	27	30	B: 10 mm ²	270 x 140 x 60	EMR-40-T440	R71204
60	3,5	0,5	27	51	B: 16 mm ²	350 x 180 x 90	EMR-60-T440	R71205
70	7,5	0,5	27	44	B: 25 mm ²	350 x 180 x 90	EMR-70-T440	R71206
100	13,8	0,75	130	69	B: 35 mm ²	420 x 200 x 130	EMR-100-T440	R71207
120	13,8	0,75	130	45	B: 50 mm ²	420 x 200 x 130	EMR-120-T440	R71208
170	23,5	0,75	130	80	B: 95 mm ²	480 x 200 x 160	EMR-170-T440	R71209
230	41	1,3	150	50	T: M12	580 x 250 x 205	EMR-230-T440	R71210
280	45	1,3	150	60	T: M12	580 x 250 x 205	EMR-280-T440	R71211
400	50	1,3	150	80	T: M12	580 x 250 x 205	EMR-400-T440	R71214
480	50	1,3	150	90	T: M12	580 x 250 x 205	EMR-480-T440	R71215

EMR, with neutral

I_n (A)	Weight (kg)	$I_{leakage}$ (mA)		Losses (W)	Terminals and screws	Dimensions (mm) A x B x C	Type	Code
		Min.	Max.					
6	1,6	0,1	27	8	B: 6 mm ²	250 x 110 x 60	EMR-06-N440	R71301
12	1,6	0,1	27	10	B: 6 mm ²	250 x 110 x 60	EMR-12-N440	R71302
20	2,2	0,1	27	15	B: 10 mm ²	270 x 140 x 60	EMR-20-N440	R71303
40	2,4	0,1	27	30	B: 10 mm ²	270 x 140 x 60	EMR-40-N440	R71304
60	3,5	0,1	27	51	B: 16 mm ²	350 x 180 x 90	EMR-60-N440	R71305
70	7,5	0,1	27	44	B: 25 mm ²	350 x 180 x 90	EMR-70-N440	R71306
100	13,8	0,5	130	69	B: 35 mm ²	420 x 200 x 130	EMR-100-N440	R71307
120	13,8	0,5	130	45	B: 50 mm ²	420 x 200 x 130	EMR-120-N440	R71308
170	23,5	0,5	130	80	B: 95 mm ²	480 x 200 x 160	EMR-170-N440	R71309

VPF

Power filter



Description

The VPF filters have been designed to reduce the high-frequency electromagnetic interferences generated by power converters as a consequence of semi-conductor switching operations.

Application

- Compulsory compliance with the electromagnetic compatibility directives for all units with electrical or electronic components.
- Avoid the propagation of electromagnetic distortions transmitted to sensitive receivers.

Features

Features	Three-phase
Maximum supply voltage	440 V a.c.
Frequency	50 ... 60 Hz
Dielectric rigidity	2.5 kV
Admissible current	see tables
Overload conditions	1.5 I _n 1 min every 20 min at 40 °C
Common mode attenuation	50 ... 60 dB
Range of frequencies	150 kHz ... 30 MHz
Environmental conditions	
Operating temperature	35 °C
Relative humidity	80 % non-condensing

Dimensions

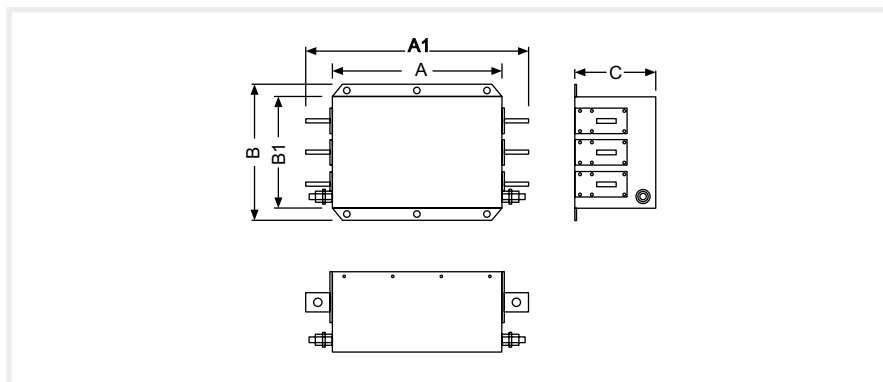

References

500 V, 50 or 60 Hz

I _n (A)	Weight (kg)	I _{leakage} Max. (mA)	Losses (W)	Screws (mm)	Dimensions (mm) A x B x C	Type	Code
150	6,5	< 6	28	∅ 9	260 x 170 x 120	VPF-3150/B	R71408
180	6,5	< 6	38	∅ 9	260 x 170 x 120	VPF-3180/B	R71409
250	7	< 6	57	∅ 11	300 x 190 x 116	VPF-3250/B	R71410
320	10,3	< 6	40	∅ 11	300 x 260 x 116	VPF-3320/B	R71411
400	10,3	< 6	50	∅ 11	300 x 260 x 116	VPF-3400/B	R71412
600	11	< 6	65	∅ 11	300 x 260 x 116	VPF-3600/B	R71413
1000	18	< 6	91	∅ 17	350 x 280 x 166	VPF-31000/B	R71414
1600	27	< 6	180	∅ 17	400 x 300 x 166	VPF-31600/B	R71415
2500	45	< 6	400	∅ 14 x 4	600 x 360 x 200	VPF-32500/B	R71416

VEF, BLC

Book-type power filter



Description

The **VEF** and **BLC** filters have been designed to reduce the high-frequency electromagnetic interferences generated by power converters as a consequence of semi-conductor switching operations. This series offers special mechanical features and a compact construction.

Application

- Compulsory compliance with the electromagnetic compatibility directives for all units with electrical or electronic components.
- Avoid the propagation of electromagnetic distortions transmitted to sensitive receivers.

Features

Features	Three-phase
Maximum supply voltage	440 V a.c.
Frequency	50 ... 60 Hz
Dielectric rigidity	2.5 kV
Admissible current	see tables
Overload conditions	1.5 I_n 1 min every 20 min at 40 °C
Common mode attenuation	50 ... 60 dB
Range of frequencies	150 kHz ... 30 MHz
Environmental conditions	
Operating temperature	35 °C
Relative humidity	80 % non-condensing

VEF, BLC

Book-type power filter

Dimensions

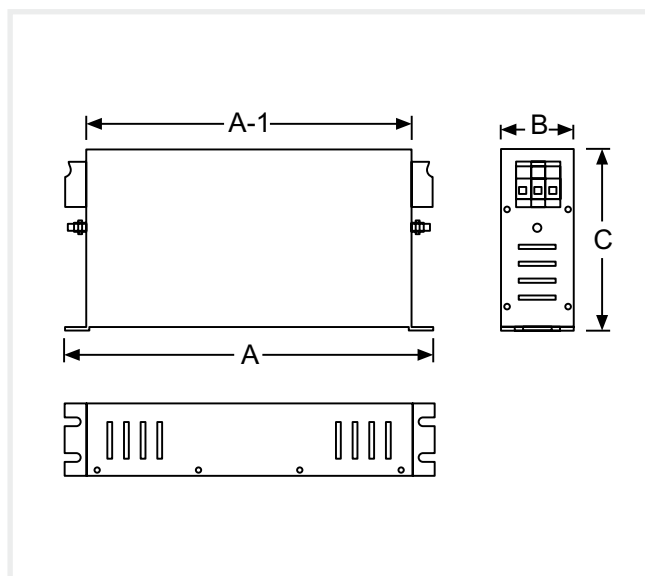

References

500 V, 50 or 60 Hz

VEF

I_n (A)	Weight (kg)	$I_{leakage}$ (mA)		Losses (W)	Terminals and screws (mm)	Dimensions (mm) A x B x C	Type	Code
		Nom.	Max.					
12	1,1	0,5	27	4,5	ø 6	255 x 50 x 126	VEF-3012	R71502
25	1,7	0,5	27	9	ø 10	255 x 50 x 126	VEF-3025	R71503
30	1,8	0,5	27	14	ø 10	255 x 50 x 126	VEF-3030	R71504
50	2,8	0,5	27	19	ø 16	335 x 60 x 150	VEF-3050	R71505
60	3,1	0,5	27	20	ø 16	335 x 60 x 150	VEF-3060	R71506
70	4	0,5	27	20	ø 25	335 x 60 x 150	VEF-3070	R71507
100	5,5	0,75	130	36	ø 35	330 x 80 x 220	VEF-3100	R71508
130	7,5	0,75	130	40	ø 50	330 x 80 x 220	VEF-3130	R71509

BLC

I_n (A)	Weight (kg)	$I_{leakage}$ (mA)		Losses (W)	Screws (mm)	Dimensions (mm) A x B x C	Type	Code
		Nom.	Max.					
7	1,1	0,5	27	4,5	ø 6	190 x 40 x 70	BLC-3007	R71601
16	1,7	0,5	27	9	ø 6	250 x 45 x 70	BLC-3016	R71602
30	1,8	0,5	27	14	ø 10	270 x 50 x 85	BLC-3030	R71603
42	2,8	0,5	27	19	ø 10	310 x 50 x 85	BLC-3042	R71604
55	3,1	0,5	27	20	ø 16	250 x 85 x 90	BLC-3055	R71605
75	4	0,5	27	20	ø 25	270 x 80 x 135	BLC-3075	R71606
100	5,5	0,75	130	36	ø 35	270 x 90 x 150	BLC-3100	R71607
130	7,5	0,75	130	40	ø 50	270 x 90 x 150	BLC-3130	R71608
180	11	0,75	130	61	ø 95	380 x 120 x 170	BLC-3180	R71609

CEM

Motor-side chokes



Description

Motor output chokes and ferrites

Application

Decrease excess currents in common mode, which cause the alterations radiated in the cable connecting to the motor, producing interferences in the control systems, data lines, etc.

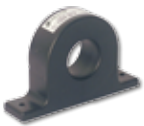

Dimensions

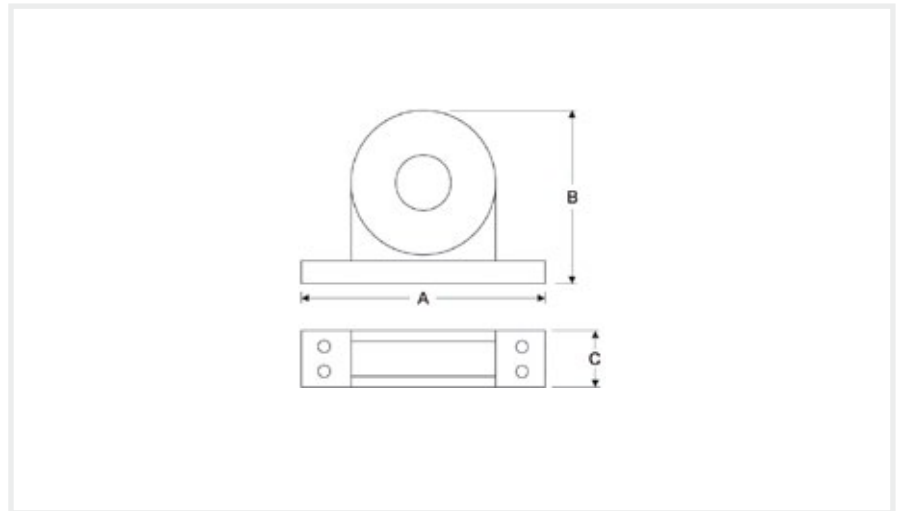

References

Motor power (kW)	Ø Interior	Weight (g)	Dimensions (mm) A x B x C	Type	Code
2,2	21 mm	80	85 x 46 x 22	CEM - 21	R7Z111
15	28.5 mm	180	105 x 62 x 25	CEM - 28.5	R7Z121
45	50 mm	50	150 x 110 x 50	CEM - 50	R7Z131
>45	58 mm	1 500	200 x 170 x 65	CEM - 58	R7Z141

FAR-Q

Hybrid absorption filter



Description

FAR-Q filters have been designed for Power factor correction purposes in networks with an average harmonic distortion, i.e., in networks where the objective is to improve the power factor and filter harmonics at the same time. Contactor switching.

Features

Features	
Power supply voltage (phase-phase)	400 V a.c. at 50 Hz 480 V a.c. at 60 Hz Other voltages, on demand
Insulation level	3 / 15 kV
Auxiliary voltage	230 V a.c.
Build features	
Cabinet material	Treated and painted steel Rack RAL 7035 Doors RAL 3005
Degree of protection	IP 20
Locking system	Lock and key
Ventilation	Natural
Fixing	On the floor
Environmental conditions	
Operating temperature	-10 ... +35 °C
Indoor	Indoor
Components	
Capacitors	CFB for FR / CFB-6B for FRE
Regulator	MAX for FR computer 8df/14df for FRE
Standards	
IEC 61642, IEC 60831, IEC 60439, IEC 60289	

FAR-Q

Hybrid absorption filter



Dimensions

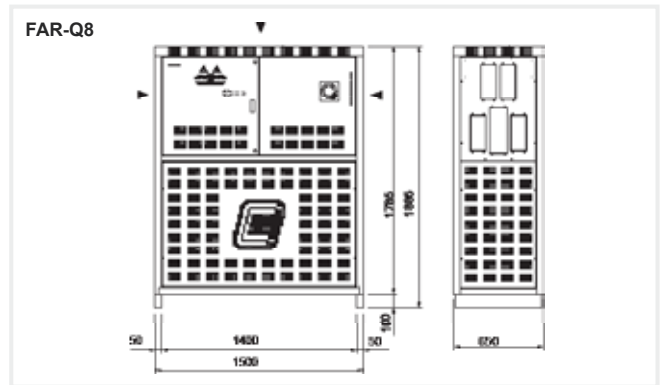
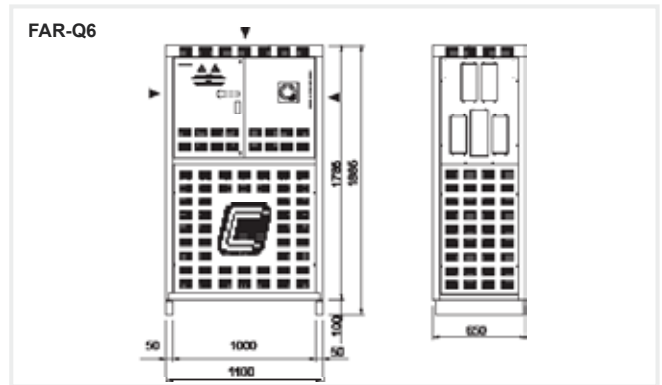

FAR-Q12 = 2 x FAR-Q6

References

FAR5-Q6 400 V / 50 Hz

kvar	Composition	I (A)	5° (A)	7° (A)	Weight (kg)	Dimensions (mm) width x height x depth	Type	Code
112,5	3 x 37.5	176	60	30	436	1100 x 1900 x 650	FAR5-Q6-112.5-400	R7C101
150	4 x 37.5	234	80	40	460	1100 x 1900 x 650	FAR5-Q6-150-400	R7C102
187,5	5 x 37.5	293	100	50	460	1100 x 1900 x 650	FAR5-Q6-187.5-400	R7C103
225	6 x 37.5	351	120	60	480	1100 x 1900 x 650	FAR5-Q8-225-400	R7C104
262,5	37.5 + (3 x 75)	410	140	70	460	1100 x 1900 x 650	FAR5-Q6-262.5-400	R7C105
300	4 x 75	469	160	80	486	1100 x 1900 x 650	FAR5-Q6-300-400	R7C106
337,5	37.5 + (4 x 75)	527	180	90	523	1100 x 1900 x 650	FAR5-Q6-337.5-400	R7C107
375	5 x 75	586	200	100	550	1100 x 1900 x 650	FAR5-Q6-375-400	R7C108

FAR5-Q8 400 V / 50 Hz

kvar	Composition	I (A)	5° (A)	7° (A)	Weight (kg)	Dimensions (mm) width x height x depth	Type	Code
412,5	37.5 + (5 x 75)	644	220	110	687	1500 x 1900 x 650	FAR5-Q8-412.5-400	R7C109
450	6 x 75	703	240	120	690	1500 x 1900 x 650	FAR5-Q8-450-400	R7C110
487,5	37.5 + (6 x 75)	761	260	130	700	1500 x 1900 x 650	FAR5-Q8-487.5-400	R7C111
525	7 x 75	820	280	140	740	1500 x 1900 x 650	FAR5-Q8-525-400	R7C112

FAR5-Q12 400 V / 50 Hz

kvar	Composition	I (A)	5° (A)	7° (A)	Weight (kg)	Dimensions (mm) width x height x depth	Type	Code
562,5	37.5 + (7 x 75)	878	300	150	950	2200 x 1900 x 650	FAR5-Q12-562.5-400	R7C113
600	8 x 75	937	320	160	980	2200 x 1900 x 650	FAR5-Q12-600-400	R7C114
637,5	37.5 + (8 x 75)	996	340	170	1009	2200 x 1900 x 650	FAR5-Q12-637.5-400	R7C115
675	9 x 75	1054	360	180	1036	2200 x 1900 x 650	FAR5-Q12-675-400	R7C116
712,5	37.5 + (9 x 75)	1113	380	190	1073	2200 x 1900 x 650	FAR5-Q12-712.5-400	R7C117
750	10 x 75	1171	400	200	1100	2200 x 1900 x 650	FAR5-Q12-750-400	R7C118

FAR-Q

Hybrid absorption filter

References

FAR6-Q6 480 V / 60 Hz

kvar	Composition	I (A)	5° (A)	7° (A)	Weight (kg)	Dimensions (mm) width x height x depth	Type	Code
105	3 x 35	166	60	30	436	1100 x 1900 x 650	FAR6-Q6-105-480	R7C401
140	4 x 35	221	80	40	460	1100 x 1900 x 650	FAR6-Q6-140-480	R7C402
175	5 x 35	276	100	50	460	1100 x 1900 x 650	FAR6-Q6-175-480	R7C403
210	6 x 35	331	120	60	480	1100 x 1900 x 650	FAR6-Q6-210-480	R7C404
245	35 + (3 x 70)	387	140	70	460	1100 x 1900 x 650	FAR6-Q6-245-480	R7C405
280	4 x 70	442	160	80	486	1100 x 1900 x 650	FAR6-Q6-280-480	R7C406
315	35 + (4 x 70)	497	180	90	523	1100 x 1900 x 650	FAR6-Q6-315-480	R7C407
350	5 x 70	552	200	100	550	1100 x 1900 x 650	FAR6-Q6-350-480	R7C408

FAR6-Q8 480 V / 60 Hz

kvar	Composition	I (A)	5° (A)	7° (A)	Weight (kg)	Dimensions (mm) width x height x depth	Type	Code
385	35 + (5 x 70)	608	220	110	687	1500 x 1900 x 650	FAR6-Q8-385-480	R7C409
420	6 x 70	663	240	120	690	1500 x 1900 x 650	FAR6-Q8-420-480	R7C410
455	35 + (6 x 70)	718	260	130	700	1500 x 1900 x 650	FAR6-Q8-455-480	R7C411
490	7 x 70	773	280	140	740	1500 x 1900 x 650	FAR6-Q8-490-480	R7C412

FAR6-Q12 480 V / 60 Hz

kvar	Composition	I (A)	5° (A)	7° (A)	Weight (kg)	Dimensions (mm) width x height x depth	Type	Code
525	35 + (7 x 70)	829	300	150	950	2200 x 1900 x 650	FAR6-Q12-525-480	R7C413
560	8 x 70	884	320	160	980	2200 x 1900 x 650	FAR6-Q12-560-480	R7C414
595	35 + (8 x 70)	939	340	170	1009	2200 x 1900 x 650	FAR6-Q12-595-480	R7C415
630	9 x 70	994	360	180	1036	2200 x 1900 x 650	FAR6-Q12-630-480	R7C416
665	35 + (9 x 70)	1050	380	190	1073	2200 x 1900 x 650	FAR6-Q12-665-480	R7C417
700	10 x 70	1105	400	200	1100	2200 x 1900 x 650	FAR6-Q12-700-480	R7C418

FARE-Q

Hybrid absorption filter



Description

FARE-Q filters have been designed for Power factor correction purposes in networks with an average harmonic distortion, i.e., in networks where the objective is to improve the power factor and filter harmonics at the same time. Static thyristor switching operations.

Features

Features	
Power supply voltage (phase-phase)	400 V a.c. at 50 Hz 480 V a.c. at 60 Hz Other voltages, on demand
Insulation level	3 / 15 kV
Auxiliary voltage	230 V a.c.
Build features	
Cabinet material	Treated and painted steel Rack RAL 7035 Doors RAL 3005
Degree of protection	IP 20
Locking system	Lock and key
Ventilation	Natural
Fixing	On the floor
Environmental conditions	
Operating temperature	-10 ... +35 °C
Indoor	Indoor
Components	
Capacitors	CFB for FR / CFB-6B for FRE
Regulator	MAX for FR computer 8df/14df for FRE
Standards	
IEC 61642, IEC 60831, IEC 60439, IEC 60289	

FARE-Q

Hybrid absorption filter



Dimensions

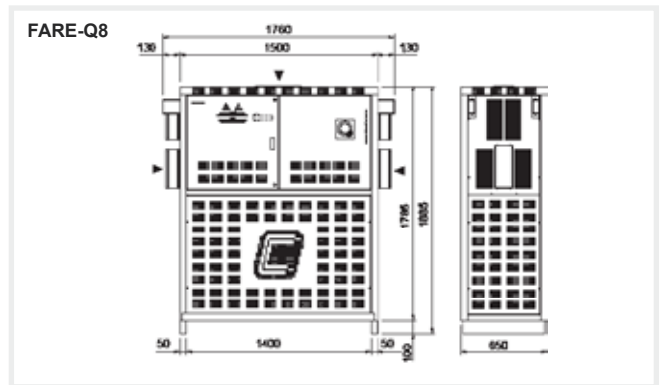
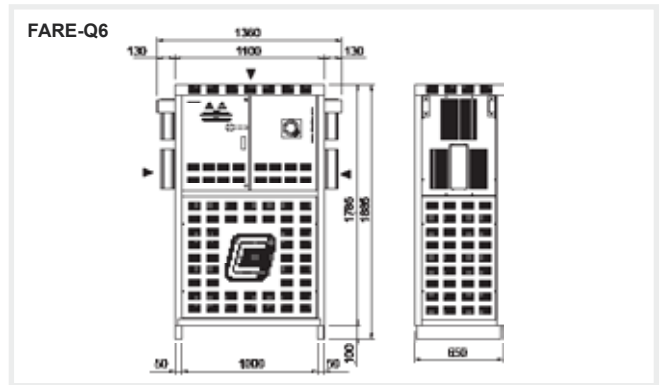

FARE-Q12 = 2 x FARE-Q6

References

FARE5-Q6 400 V / 50 Hz

kvar	Composition	I (A)	5° (A)	7° (A)	Weight (kg)	Dimensions (mm) width x height x depth	Type	Code
112,5	3 x 37.5	176	60	30	436	1360 x 1900 x 650	FARE5-Q6-112.5-400	R7D101
150	4 x 37.5	234	80	40	460	1360 x 1900 x 650	FARE5-Q6-150-400	R7D102
187.5	5 x 37.5	293	100	50	460	1360 x 1900 x 650	FARE5-Q6-187.5-400	R7D103
225	6 x 37.5	351	120	60	480	1360 x 1900 x 650	FARE5-Q8-225-400	R7D104
262,5	37.5 + (3 x 75)	410	140	70	460	1360 x 1900 x 650	FARE5-Q6-262.5-400	R7D105
300	4 x 75	469	160	80	486	1360 x 1900 x 650	FARE5-Q6-300-400	R7D106
337,5	37.5 + (4 x 75)	527	180	90	523	1360 x 1900 x 650	FARE5-Q6-337.5-400	R7D107
375	5 x 75	586	200	100	550	1360 x 1900 x 650	FARE5-Q6-375-400	R7D108

FARE5-Q8 400 V / 50 Hz

kvar	Composition	I (A)	5° (A)	7° (A)	Weight (kg)	Dimensions (mm) width x height x depth	Type	Code
412,5	37.5 + (5 x 75)	644	220	110	687	1760 x 1900 x 650	FARE5-Q8-412.5-400	R7D109
450	6 x 75	703	240	120	690	1760 x 1900 x 650	FARE5-Q8-450-400	R7D110
487,5	37.5 + (6 x 75)	761	260	130	700	1760 x 1900 x 650	FARE5-Q8-487.5-400	R7D111
525	7 x 75	820	280	140	740	1760 x 1900 x 650	FARE5-Q8-525-400	R7D112

FARE5-Q12 400 V / 50 Hz

kvar	Composition	I (A)	5° (A)	7° (A)	Weight (kg)	Dimensions (mm) width x height x depth	Type	Code
562,5	37.5 + (7 x 75)	878	300	150	950	2720 x 1900 x 650	FARE5-Q12-562.5-400	R7D113
600	8 x 75	937	320	160	980	2720 x 1900 x 650	FARE5-Q12-600-400	R7D114
637,5	37.5 + (8 x 75)	996	340	170	1009	2720 x 1900 x 650	FARE5-Q12-637.5-400	R7D115
675	9 x 75	1054	360	180	1036	2720 x 1900 x 650	FARE5-Q12-675-400	R7D116
712,5	37.5 + (9 x 75)	1113	380	190	1073	2720 x 1900 x 650	FARE5-Q12-712.5-400	R7D117
750	10 x 75	1171	400	200	1100	2720 x 1900 x 650	FARE5-Q12-750-400	R7D118

FARE-Q

Hybrid absorption filter

References

FARE6-Q6 480 V / 60 Hz

kvar	Composition	I (A)	5° (A)	7° (A)	Weight (kg)	Dimensions (mm) width x height x depth	Type	Code
105	3 x 32.5	166	60	30	436	1360 x 1900 x 650	FARE6-Q6-105-480	R7D401
140	4 x 32.5	221	80	40	460	1360 x 1900 x 650	FARE6-Q6-140-480	R7D402
175	5 x 32.5	276	100	50	460	1360 x 1900 x 650	FARE6-Q6-175-480	R7D403
210	6 x 32.5	331	120	60	480	1360 x 1900 x 650	FARE6-Q6-210-480	R7D404
245	32.5 + (3 x 65)	387	140	70	460	1360 x 1900 x 650	FARE6-Q6-245-480	R7D405
280	4 x 65	442	160	80	486	1360 x 1900 x 650	FARE6-Q6-280-480	R7D406
315	32.5 + (4 x 65)	497	180	90	523	1360 x 1900 x 650	FARE6-Q6-315-480	R7D407
350	5 x 65	552	200	100	550	1360 x 1900 x 650	FARE6-Q6-350-480	R7D408

FARE6-Q8 480 V / 60 Hz

kvar	Composition	I (A)	5° (A)	7° (A)	Weight (kg)	Dimensions (mm) width x height x depth	Type	Code
385	32.5 + (5 x 65)	608	220	110	687	1760 x 1900 x 650	FARE6-Q8-385-480	R7D409
420	6 x 65	663	240	120	690	1760 x 1900 x 650	FARE6-Q8-420-480	R7D410
455	32.5 + (6 x 65)	718	260	130	700	1760 x 1900 x 650	FARE6-Q8-455-480	R7D411
490	7 x 65	773	280	140	740	1760 x 1900 x 650	FARE6-Q8-490-480	R7D412

FARE6-Q12 480 V / 60 Hz

kvar	Composition	I (A)	5° (A)	7° (A)	Weight (kg)	Dimensions (mm) width x height x depth	Type	Code
525	32.5 + (7 x 65)	829	300	150	950	2720 x 1900 x 650	FARE6-Q12-525-480	R7D413
560	8 x 65	884	320	160	980	2720 x 1900 x 650	FARE6-Q12-560-480	R7D414
595	32.5 + (8 x 65)	939	340	170	1009	2720 x 1900 x 650	FARE6-Q12-595-480	R7D415
630	9 x 65	994	360	180	1036	2720 x 1900 x 650	FARE6-Q12-630-480	R7D416
665	32.5 + (9 x 65)	1050	380	190	1073	2720 x 1900 x 650	FARE6-Q12-665-480	R7D417
700	10 x 65	1105	400	200	1100	2720 x 1900 x 650	FARE6-Q12-700-480	R7D418

FAR-H-AP5

Regulated absorption filter
5th Harmonic absorption



Description

FAR-H filters have been designed to reduce the level of harmonics in networks with a high current distortion rate. Therefore, the **FAR-H** absorption filters used to regulate the level of harmonics are classified in steps, depending on the existing load.

FAR-H-AP5 have been designed to absorb 5th order harmonic currents.

Features

Features	
Power supply voltage (phase-phase)	400 V a.c. at 50 Hz 480 V a.c. at 60 Hz
Auxiliary voltage	230 V a.c.
Build features	
Cabinet material	Treated and painted steel Rack RAL 1013 Doors RAL 3005
Degree of protection	IP 20
Locking system	Lock and key
Ventilation	Natural
Fixing	On the floor
Environmental conditions	
Operating temperature	-10 ... +35 °C
Indoor	Indoor
Components	
Capacitors	CFB
Regulator	ROYAL Relay
Standards	
IEC 61642, IEC 60831, IEC 60439, IEC 60289	

FAR-H-AP5

Regulated absorption filter
5th Harmonic absorption



Dimensions

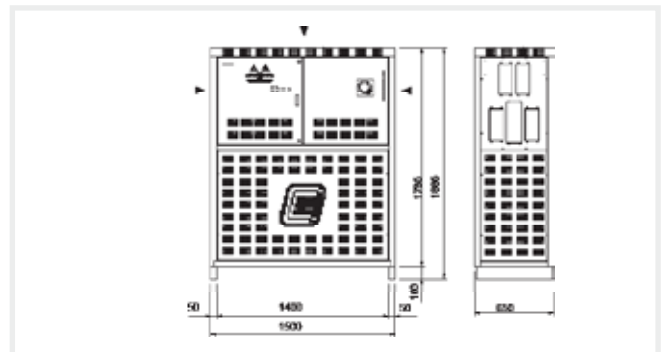
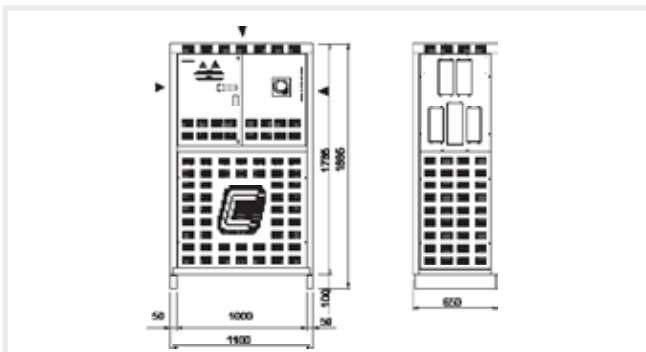
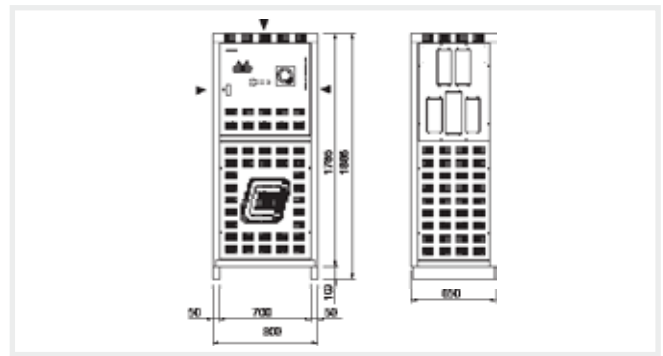

References

FAR-H -AP5 400 V / 50 Hz

5° (A)	Composition	kvar	I (A)	Weight (kg)	Dimensions (mm) width x height x depth	Type	Code
66	2 x 33(5°)	34	82	340	800 x 1900 x 650	FAR5-HP-AP5-66-400	R7E020
99	3 x 33(5°)	51	123	350	800 x 1900 x 650	FAR5-HP-AP5-99-400	R7E030
132	4 x 33(5°)	68	164	365	800 x 1900 x 650	FAR5-HP-AP5-132-400	R7E040
165	5 x 33(5°)	85	206	395	800 x 1900 x 650	FAR5-HP-AP5-165-400	R7E050
198	6 x 33(5°)	102	247	560	1100 x 1900 x 650	FAR5-H6-AP5-198-400	R7E060
231	7 x 33(5°)	119	288	670	1500 x 1900 x 650	FAR5-H8-AP5-231-400	R7E070
264	8 x 33(5°)	136	329	710	1500 x 1900 x 650	FAR5-H8-AP5-264-400	R7E080
320	4 x 80(5°)	164	398	486	1100 x 1900 x 650	FAR5-H6-AP5-320-400	R7E0D0
400	5 x 80(5°)	205	498	550	1100 x 1900 x 650	FAR5-H6-AP5-400-400	R7E0E0
480	6 x 80(5°)	246	597	614	1100 x 1900 x 650	FAR5-H6-AP5-480-400	R7E0F0
560	7 x 80(5°)	287	697	750	1500 x 1900 x 650	FAR5-H8-AP5-560-400	R7E0G0
640	8 x 80(5°)	328	796	870	1500 x 1900 x 650	FAR5-H8-AP5-640-400	R7E0H0

FAR-H -AP5 480 V / 60 Hz

5° (A)	Composition	kvar	I (A)	Weight (kg)	Dimensions (mm) width x height x depth	Type	Code
70	2 x 35(5°)	30	82	340	800 x 1900 x 650	FAR6-HP-AP5-70-480	R7F720
105	3 x 35(5°)	45	123	350	800 x 1900 x 650	FAR6-HP-AP5-105-480	R7F730
140	4 x 35(5°)	60	165	365	800 x 1900 x 650	FAR6-HP-AP5-140-480	R7F740
175	5 x 35(5°)	75	206	390	800 x 1900 x 650	FAR6-HP-AP5-175-480	R7F750
210	6 x 35(5°)	90	247	560	1100 x 1900 x 650	FAR6-H6-AP5-210-480	R7F760
245	7 x 35(5°)	105	288	670	1500 x 1900 x 650	FAR6-H8-AP5-245-480	R7F770
265	5 x 53(5°)	110	309	550	1100 x 1900 x 650	FAR6-H6-AP5-265-480	R7F7E0
280	8 x 35(5°)	120	329	710	1500 x 1900 x 650	FAR6-H8-AP5-280-480	R7F780
318	6 x 53(5°)	132	371	614	1100 x 1900 x 650	FAR6-H6-AP5-318-480	R7F7F0
371	7 x 53(5°)	154	432	750	1100 x 1900 x 650	FAR6-H6-AP5-371-480	R7F7G0
424	8 x 53(5°)	176	494	870	1500 x 1900 x 650	FAR6-H8-AP5-424-480	R7F7H0

FAR-H-AP57

Regulated absorption filter
5th and 7th Harmonic absorption



Description

FAR-H filters have been designed to reduce the level of harmonics in networks with a high current distortion rate. Therefore, the **FAR-H** absorption filters used to regulate the level of harmonics are classified in steps, depending on the existing load.

FAR-H-AP57 have been designed to absorb 5th and 7th order harmonic currents.

Features

Features	
Power supply voltage (phase-phase)	400 V a.c. at 50 Hz 480 V a.c. at 60 Hz
Auxiliary voltage	230 V a.c.
Build features	
Cabinet material	Treated and painted steel Rack RAL 1013 Doors RAL 3005
Degree of protection	IP 20
Locking system	Lock and key
Ventilation	Natural
Fixing	On the floor
Environmental conditions	
Operating temperature	-10 ... +35 °C
Indoor	Indoor
Components	
Capacitors	CFB
Regulator	ROYAL Relay
Standards	IEC 61642, IEC 60831, IEC 60439, IEC 60289

FAR-H-AP57

Regulated absorption filter
5th and 7th Harmonic absorption

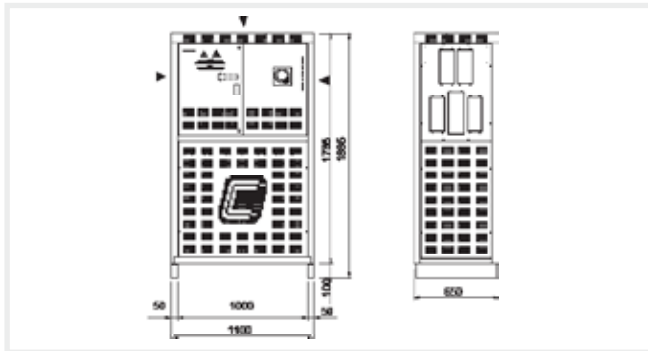

Dimensions

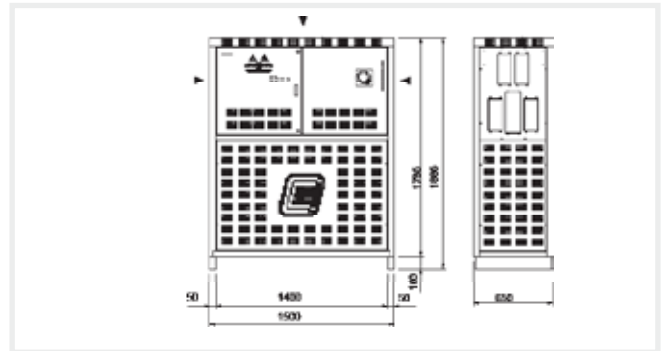
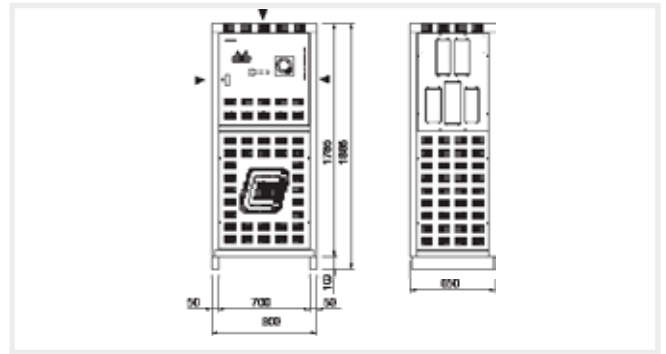

References

FAR-H -AP57 400 V / 50 Hz

5° (A)	7° (A)	Composition	kvar	I (A)	Weight (kg)	Dimensions (mm) width x height x depth	Type	Code
33	33	33(5°) + 33(7°)	34	68	340	800 x 1900 x 650	FAR5-HP-AP57-66-400	R7E011
66	33	33(5°) + (33(5°) + 33(7°))	51	90	350	800 x 1900 x 650	FAR5-HP-AP57-99-400	R7E021
66	66	2 x (33(5°) + 33(7°))	68	115	365	800 x 1900 x 650	FAR5-HP-AP57-132-400	R7E022
99	66	33(5°) + 2 x (33(5°) + 33(7°))	85	146	390	800 x 1900 x 650	FAR5-HP-AP57-165-400	R7E032
99	99	3 x (33(5°) + 33(7°))	102	173	560	1100 x 1900 x 650	FAR5-H6-AP57-198-400	R7E033
132	99	33(5°) + 3 x (33(5°) + 33(7°))	119	203	670	1500 x 1900 x 650	FAR5-H8-AP57-231-400	R7E043
132	132	4 x (33(5°) + 33(7°))	136	231	710	1500 x 1900 x 650	FAR5-H8-AP57-264-400	R7E044
160	160	2 x (80(5°) + 80(7°))	164	279	486	1100 x 1900 x 650	FAR5-H6-AP57-320-400	R7E0BB
240	160	80(5°) + 2 x (80(5°) + 80(7°))	205	354	550	1100 x 1900 x 650	FAR5-H6-AP57-400-400	R7E0CB
240	240	3 x (80(5°) + 80(7°))	246	419	614	1100 x 1900 x 650	FAR5-H6-AP57-480-400	R7E0CC
320	240	80(5°) + 3 x (80(5°) + 80(7°))	287	492	714	1500 x 1900 x 650	FAR5-H8-AP57-560-400	R7E0DC
320	320	4 x (80(5°) + 80(7°))	328	559	870	1500 x 1900 x 650	FAR5-H8-AP57-640-400	R7E0DD

FAR-H -AP57 480 V / 60 Hz

5° (A)	7° (A)	Composition	kvar	I (A)	Weight (kg)	Dimensions (mm) width x height x depth	Type	Code
35	35	35(5°) + 35(7°)	30	66	340	800 x 1900 x 650	FAR6-HP-AP57-70-480	R7F711
70	35	35(5°) + (35(5°) + 35(7°))	45	102	350	800 x 1900 x 650	FAR6-HP-AP57-105-480	R7F721
70	70	2 x (35(5°) + 35(7°))	60	132	365	800 x 1900 x 650	FAR6-HP-AP57-140-480	R7F722
105	70	35(5°) + 2 x (35(5°) + 35(7°))	75	166	390	800 x 1900 x 650	FAR6-HP-AP57-175-480	R7F732
105	105	3 x (35(5°) + 35(7°))	90	197	560	1100 x 1900 x 650	FAR6-H6-AP57-210-480	R7F733
140	105	35(5°) + 3 x (35(5°) + 35(7°))	105	232	670	1500 x 1900 x 650	FAR6-H8-AP57-245-480	R7F743
159	106	53(5°) + 2 x (53(5°) + 53(7°))	110	248	550	1100 x 1900 x 650	FAR6-H6-AP57-265-480	R7F7CB
140	140	4 x (35(5°) + 35(7°))	120	263	710	1500 x 1900 x 650	FAR6-H8-AP57-280-480	R7F744
159	159	3 x (53(5°) + 53(7°))	132	295	614	1100 x 1900 x 650	FAR6-H6-AP57-318-480	R7F7CC
212	159	53(5°) + 3 x (53(5°) + 53(7°))	154	346	750	1100 x 1900 x 650	FAR6-H6-AP57-371-480	R7F7DC
212	212	4 x (53(5°) + 53(7°))	176	393	870	1500 x 1900 x 650	FAR6-H8-AP57-424-480	R7F7DD

R.7

Harmonic filters and EMI

+ info: central@circutor.es

www.circutor.com



CIRCUTOR, SA - Vial Sant Jordi, s/n
08232 Viladecavalls (Barcelona) Spain
Tel. (+34) 93 745 29 00 - Fax: (+34) 93 745 29 14
central@circutor.es

