

R.8/9

MV capacitors banks and accessories



MV capacitors banks and accessories

Introduction	R8/9- 3
---------------------------	----------------

R.8 - MV capacitors and accessories

CHV-M

Single-phase capacitor (indoor and outdoor use)	R8-13
---	--------------

CHV-T

Three-phase capacitor (Indoor use, with fuses and discharge resistor, internal)	R8-17
---	--------------

LVC

Three-phase contactor for MV capacitors.	R8-19
---	--------------

RMV

Choke reactor for capacitor banks	R8-20
---	--------------

R.9 - MV Capacitor banks

CIRKAP-C

Fixed or automatic capacitor banks in cabinet	R9-22
---	--------------

CIRKAP-GP

High-powered capacitor banks in cabinet	R9-25
---	--------------

CIRKAP-CMFR / CMAR

Fixed or automatic capacitor banks in cabinet with detuned filters	R9-25
--	--------------

CIRKAP-B

Capacitor banks in frames	R9-26
---------------------------------	--------------

Medium Voltage Power Factor correction

MV Power factor correction is directly related to the different aspects that assist the technical management of transport and distribution networks. These are:

- **Power quality.** This involves the increase in the levels of voltage in substation busbars and line ends.

- **Optimisation of the installation's cost of operation.** In other words, the decrease of the reactive energy and, therefore, the reduction of apparent power entail two aspects of a strong technical relevance:

- Reduction of losses
- Increase in the performance of transformers and installations

- **Reduction of the economic cost of energy.**

An in-depth description of each point is provided in the following sections.

Supply quality, voltage level

There are two cases: control of voltage in MV substation busbars and line ends.

► Control of voltage in substation busbars

One of the critical points in the distribution of electrical energy is maintaining voltage in line ends. Distribution companies usually maintain the MV levels above its nominal value.

Therefore, MV capacitor banks are used. In fact, the connection of capacitor banks has an associated increase in voltage in the connection points.

The **IEC 60871-1** Standard facilitates the expression to calculate the increase in voltage produced after the connection of capacitors (See table below), depending on the characteristics of the network where the capacitor bank is connected.

The power, type of unit and level of division depend on the criteria used by distribution Companies.

However, the division of total power in different steps can be used to improve the levels of voltage under different substation load conditions, avoiding an excess capacitive power in the network.

► Control of voltage in line ends

In the case of very long MV lines, the voltage in branch points might be decreased by the effects of the conductor cable. This is quite important in areas with a rural overhead distribution or with a high level of dispersion of consumers.

The connection of capacitor banks at the end of a line allows a decrease of voltage drops at the line end, as well as the reduction in the level of cable losses.

Optimisation of the installation's cost of operation

The generation, transmission and distribution of energy entails an important amount of energy losses

In general, these losses are divided in the following:

- Generation losses and substations
- Losses in the transmission system
- Losses in MV/HV substations
- Losses in the distribution lines



Comprehensive information about the losses in the MV distribution lines is shown next.

Reduction of losses in MV lines.

Capacitor banks can be installed to decrease the level of losses in a MV distribution line.

In fact, the installation of the capacitor will produce a direct reduction of the reactive energy (Q network) and apparent energy requested from the system.

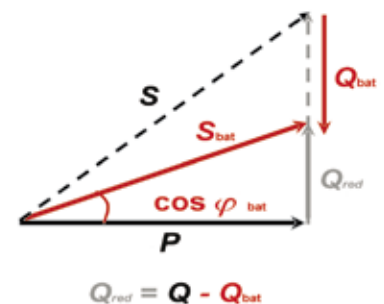

Therefore, in accordance with the direct relationship between current power values, the value of Joule effect losses will decrease.

The following table shows the expressions required for the calculation of Joule effect losses, the reactive energy consumption of the cable and decrease in the losses when a capacitor bank is connected.

Increase of the voltage when a capacitor bank is connected **IEC 60871-1**

$$\Delta U(\%) = \frac{Q_{\text{bat}}}{S_{\text{cc}}} \cdot 100$$

Line voltage drops

$$U(\%) = \frac{P \cdot L}{10 \cdot U^2} \cdot (R_1 + X_1 \tan \varphi)$$

Joule effect losses in a line

$$P(\text{kW}) = 3 \cdot R_1 \cdot I^2 \cdot L$$

Reactive energy consumption in a line

$$Q(\text{kvar}) = 3 \cdot X_1 \cdot I^2 \cdot L$$

Reduced losses after the connection of a capacitor bank

$$\Delta P = R_1 \cdot \frac{P^2 + (Q - Q_{\text{bat}})^2}{U^2} \cdot L$$

Units used to understand the calculation expressions:	
P	active power transmitted by the line in kW
Q	reactive energy absorbed without capacitor banks
Q_{bank}	power of the capacitor bank in MV·A
I	current
U	Network voltage in kV
R_1	resistance of the cable in Ω/km
X_1	reactor of the cable in Ω/km
L	length of the line in km
S_{cc}	short-circuit power in the connection point in MV·A.

This point is important when making the economic assessment of the performance of an installation, since there is an added “hidden cost” to the payment for reactive energy consumption, which is represented by the active energy dissipated during distribution.

Line and cable discharge

The decrease in apparent power after the connection of a capacitor bank entails two immediate consequences:

- Decrease of the load transmitted through cables
- Increase of the supply capacity of transformers
- Increase of the voltage at the end of the line

Example of a reduction of Joule effect losses in an overhead distribution line system.

In this case, the evolution of the line losses and voltage drops is analysed in a distribution system rated at 20 kV with no capacitor banks connected.

The effect of capacitor banks in a MV overhead distribution line in a rural area is compared between banks, where there are two distribution centres, A and B.

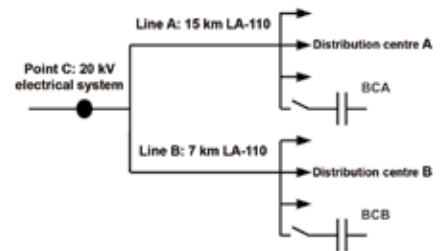

State of loads with no capacitor banks connected

The system's power situation is shown on the following table:

The connection conditions in the connection point with electrical system C are not very good, i.e., the apparent power volume is high and the power factor is low.

	C Connection point	A Distribution Centre	B Distribution Centre
Active power (MW)	7,39	2,7	4,39
Reactive energy (Mvar)	3,70	1,23	2,13
Apparent power (MV·A)	8,26	2,97	4,88
cos φ	0,89	0,91	0,9
Joule effect losses (kW)	-	114,5	185
reactive consumed by the line (kvar)	-	129	208
Voltage drops (%)	-	5,2	5,25

Situation with connected capacitor banks

A 1,100 kvar capacitor bank at 20 kV is connected to distribution centre A (BCA) and a 2,000 kvar capacitor bank at 20 kV is connected to distribution centre B (BCB) to improve the network conditions.

The balance of power is modified, as shown on the following table:

	C Connection point	A Distribution Centre with BCA	B Distribution Centre with BCB
Active power (MW)	7,33	2,7	4,39
Reactive energy (Mvar)	0,54	0,13	0,13
Apparent power (MV·A)	7,36	2,7	4,39
cos φ	0,99	0,99	0,99
Joule effect losses (kW)	-	94	150
Reactive consumed by the line (kvar)	-	106	170
Voltage drops (%)	-	3,9	3,8
Active power savings (kW)	-	20	35

In this case, the conditions in C have been substantially optimised. In addition, losses have decreased throughout the lines and the levels of voltage have increased in the distribution centres.

Therefore, the operation and performance of the line has been optimised and the level of voltage is guaranteed for users.

Conclusions

Capacitor banks are vital for the adequate technical and economic management of the electrical system, optimising its operation.

Technical optimisation

- Helping control voltage throughout the transmission and distribution system
- Discharging lines and transformers
- Reduction of the level of losses throughout the system

Economic optimisation

Reduction of the cost of energy with the decrease of the reactive energy consumed

Reduction of the hidden cost of losses in transmission and distribution lines

More efficient optimisation of installations

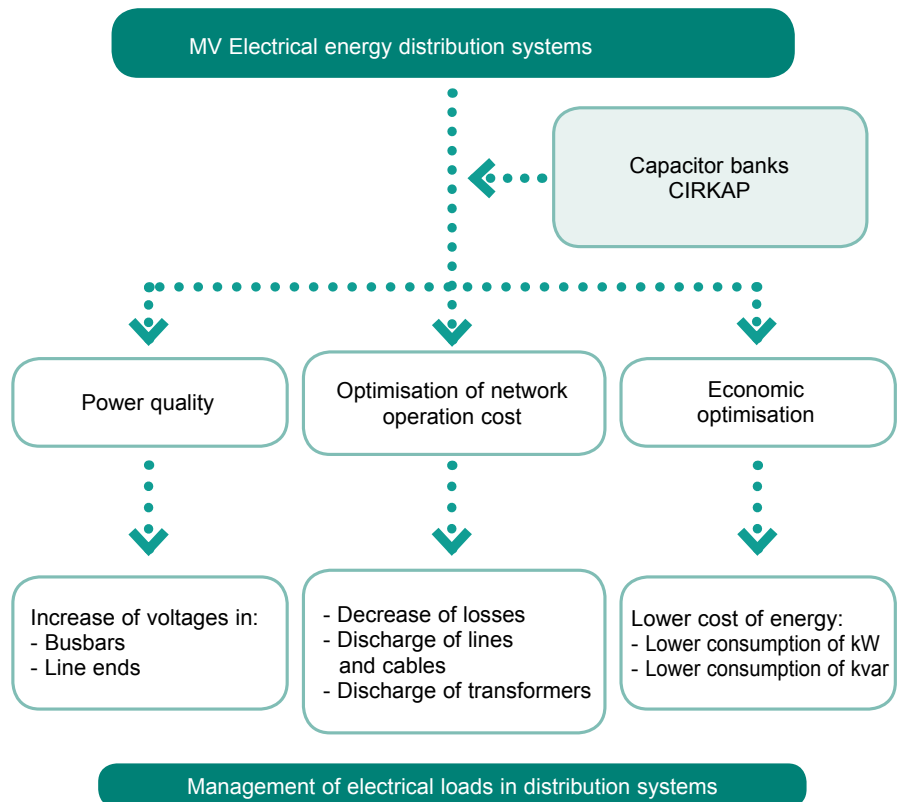

Where to compensate in MV

Electrical energy generation, transmission and distribution

Reactive energy transmission and distribution throughout the electrical system is noteworthy, as stated above. Therefore, the reactive energy must be compensated in determined points of the electrical network. These are:

- Generation stations: Such as low-powered hydroelectric power plants and wind farms
- Receiving / distribution substations. (for example, reception 400 kV, distribution at 20 kV)
- Distribution centres

Industrial installations with MV distribution and consumption

In general, the installations that distribute and consume MV are likely to be compensated.

For example:

- Pumping stations
- Mining
- Industry: cement, chemical, steel, etc.

There are transformers, asynchronous motors or electric arc equipment in all of these industries, which are large reactive energy consumers.

MV distribution and LV consuming installations

In MV receiving installations with a distribution and consumption of LV, the compensation must always be carried out in Low Voltage. The reasons are:

- Low power is cheaper in LV
- More accurate regulation

However, when there is a high number of LV / MV transformers, we recommend the installation of LV regulated capacitor banks and a fixed MV section.

Components for MV capacitor banks

CHV Capacitors



Configuration of capacitors

► Single-phase

Capacitor with two terminals. Capacitor bank installation in a star or double star arrangement. Common in networks with a power rating that exceeds 11 kV or in capacitor banks with lower voltages and higher power levels.

► Three-phase

Capacitor with three terminals. Installation in low and medium-powered capacitor banks in networks with a power rating of up to 11 kV.

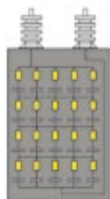

Capacitor composition

The CHV Medium Voltage capacitors are composed of different basic capacitive elements. These basic units are connected in groups in series and in parallel with the purpose of achieving the power and voltage levels required.

After assembling the set of elements, the set is introduced in a stainless steel box, adding the porcelain terminals and impregnating the elements in oil (biodegradable), guaranteeing the unit's perfect insulation and operation.

Insulation levels (BIL)

Maximum voltage supported by the material in two cases, in accordance with the IEC Standard:

- **At the industrial frequency during 1 minute.** Verification of the insulation of the unit, simulating a high network voltage (kV_{ef})
- **Impulse, ray-type (shockwave) 1.2 / 50 μ s.** Verification of the insulation of the unit, simulating a ray discharge (kV_{peak})

In the case of three-phase capacitors, the degree of insulation corresponds to that immediately above its nominal voltage.

Example: Three-phase capacitor CHV-T 300 kvar, 6.6 kV. Level of insulation 7.2 kV

In single-phase capacitors, the selection criteria is different to that of three-phase capacitors. The levels of insulation correspond to the same levels of the network when it is connected to the capacitor bank in equipment that is not insulated from earth (IEC 60.671-1).

Example: Capacitor bank, 3 Mvar at 20 kV. Composed of 6 units, 500 kvar, 11.56 kV. Level of insulation of capacitors 24 kV, (50/125 kV)

Leakage lines

Capacitor insulator flash-over perimeter. Directly related to the levels of pollution.

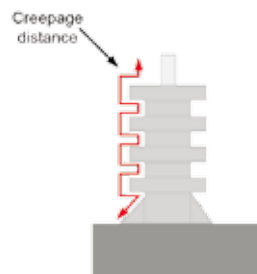

Insulation level (kV)	Voltage at industrial frequency (kV_{ef})	Shockwave (kV_{peak})	Leakage lines (mm)
7,2	20	60	190
12	28	75	190
17,5	38	95	300
24	50	125	435
36	70	170	600

Table 1

Pollution levels

The pollution level defines the environmental contamination existing in the place where equipment is installed. Therefore, to avoid insulation defects as a consequence of flash-over, the greater the degree of environmental pollution, the greater the leakage of insulators.

It is expressed in mm / kV. In other words, the relationship between the insulator leakage line and network voltage. The pollution levels defined are shown on the following table:

Classification	Pollution level
Low	16 mm/kV
Medium	20 mm/kV
High	25 mm/kV
Very high	31 mm/kV

Protection of capacitors with internal fuses

The capacitor, as any element in an electrical installation, must be capable of eliminating the defects that can be caused inside. To do so, all basic capacitive elements of the capacitor are protected with an internal fuse.

In case of a defect in a basic capacitive element, the healthy elements will be discharged in parallel to the faulty element. The discharge will immediately melt the internal fuse of the damaged unit. This system has a series of advantages that are classified in two groups:

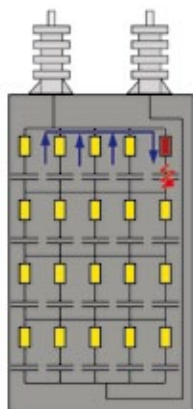

Operational advantages

- Immediate disconnection of the damaged element
- Minimum generation of gases inside the capacitor, therefore, a very low internal overpressure effect
- Continuity of the service. The removal of the damaged unit means that the unit can remain connected. Optional planning of the capacitor bank's maintenance
- Simpler maintenance

Design advantages

- Increase capacitor power
- Use of less capacitors in each capacitor bank
- Reduction of the size of frames or cabinet
- Cheaper capacitor banks

MV Capacitor banks

Configuration of capacitor banks

The use of different configurations is common in MV capacitor banks. These depend on the type of capacitor used and, above all, on the installation's electrical parameters.

Capacitor banks, three-phase capacitors

These units are useful in industrial installations, since they are capable of hosting low and medium-powered applications in small dimensions.

The maximum service voltage is 11 kV and the maximum power is 1.4 Mvar.

The most common applications are:

- Compensation of motors
- Compensation of transformers
- Automatic capacitor banks

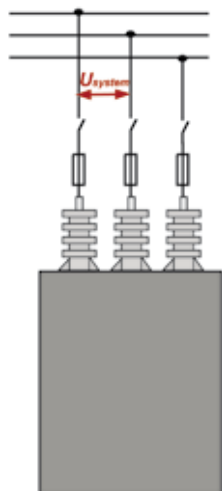

Capacitor banks with single-phase capacitors connected in a double-star arrangement

This is the most common configuration in medium and large-powered applications.

The double-star is formed by two stars joined by a common neutral.

A current transformer is connected to the neutral to detect the default currents of capacitors.

This arrangement of capacitors can be used to operate the unit, whatever the power and voltage levels required, based on the use of standard capacitors.

In fact, the capacitor or group of capacitors in each branch will have an applied voltage corresponding to the phase voltage, as seen on the figure.

After defining the voltage of each capacitor and, therefore, the number of units, so the power of each capacitor is defined.

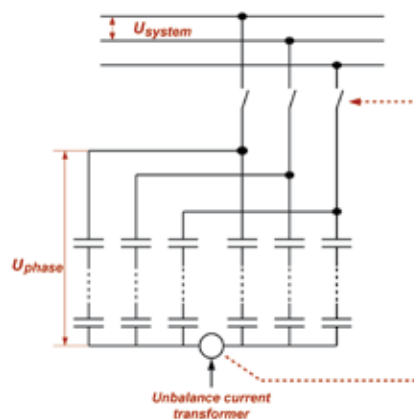

$$Q_{\text{capacitor}} = \frac{Q_{\text{bank}}}{\text{Number of capacitor}} :$$

This configuration is used in the following cases:

- Networks with service voltages exceeding 11 kV
- Networks with voltages under 11 kV and power levels above 1.6 Mvar

Capacitor banks with single-phase capacitors connected in a star arrangement

The application of this configuration is limited to low-powered capacitor banks, which can not be resolved with three-phase capacitors due to the working voltage.

A practical case is, for example, a 450 kvar capacitor bank at 15 kv.

This case will be resolved with 3 capacitors, with a nominal voltage of 150 kvar at 8.67 kVl.

The level of insulation of capacitors corresponds to that of the network, i.e., 17.5 kV.

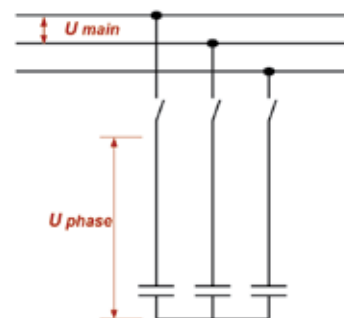

Compensation method

The compensation method in MV installations is carried out with a fixed or automatic system, as in LV installations. It depends on the type of installation, its configuration, the load ratio, as well as the purpose for which the unit was installed.

Fixed compensation

When the reactive energy levels are high and an important portion of these levels is more or less constant, a fixed compensation unit is installed. This is common in installations with a connection to High Voltage networks and Medium Voltage distribution.

Another application is in industrial installations with a reduced number of receivers and where the operating ratios do not require the machines to interrupt their operation simultaneously.

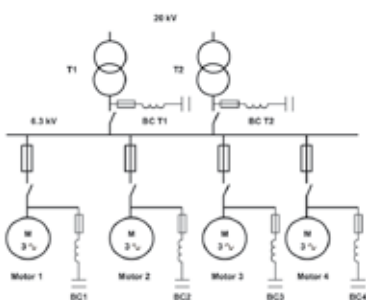
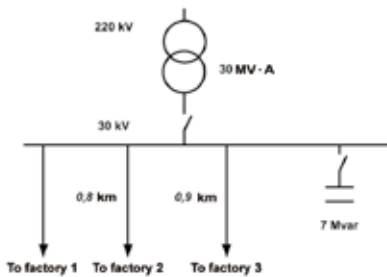

Automatic compensation

The installation of a unit that can follow the fluctuations is required in installations with large variations in load.

An example is the distribution branch of an industry at 6.3 kV with MV loads and LV transformers, as shown on the figure.

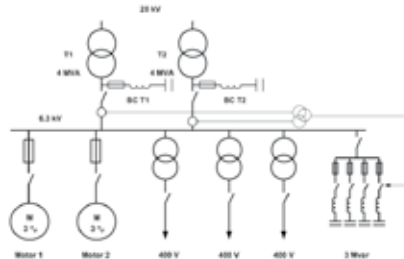

Protection of capacitor banks

In general, capacitor bank protection systems are divided in external and internal protections.

Internal protection

Internal protection systems protect units against defects inside capacitors. This type of protection is guaranteed by internal fuses. In capacitor banks configured in a double star arrangement, this is combined with an unbalanced protection. This system is composed of a current transformer and an associated relay.

In case of an internal fault in one of the capacitors, an unbalanced current will flow through the capacitor.

This current is detected by the current transformer. The associated relay will send an order to disconnect the switching and/or protection unit.

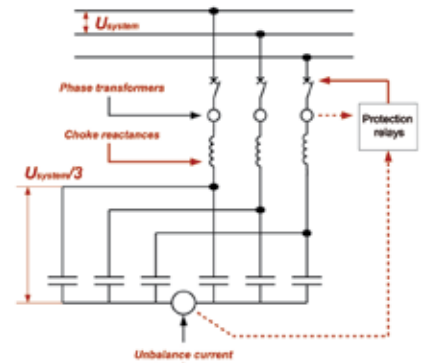

External protection

The protection systems used in capacitor banks depend on the configuration of the bank and its application.

General component design criteria

In accordance with the IEC 60871-1 Standard, capacitors are designed to support a 30% overload of permanent current.

Therefore, the Standard recommends that the components in the capacitor bank support a maximum of 1.43 times the nominal current. This criterion is applicable to the following:

- Power cables
- General devices
- Choke REACTORS

CAPACITOR BANKS WITH THREE-PHASE CAPACITORS	CAPACITOR BANKS WITH A DOUBLE-START ARRANGEMENT
Nominal voltages ≤ 11 kV Capacitor bank power ≤ 1.4 Mvar	Nominal voltages > 11 kV Capacitor bank power > 1.4 Mvar
<p>Fixed for motor: High rupture power fuses (HRP) with meltdown indication.</p> <p>Automatic: HRP fuses combined with a contactor</p>	<p>Automatic switch, with the following protection elements:</p> <ul style="list-style-type: none"> • Overload and short-circuit • Homopolar • Unbalance <p>Notes:</p> <ul style="list-style-type: none"> • Overload protection is recommended in busbars. • The protection system can be installed on the same capacitor bank or in the centre of MV cabinet

How to select a Medium Voltage capacitor bank

The **CIRKAP** capacitor bank series offers a full range of Medium Voltage capacitor banks in fixed and automatic versions (only in the case of capacitor banks in the cabin).

The **CIRKAP** capacitor banks are divided in two main groups:

- **CIRKAP-C**
- **CIRKAP-B**

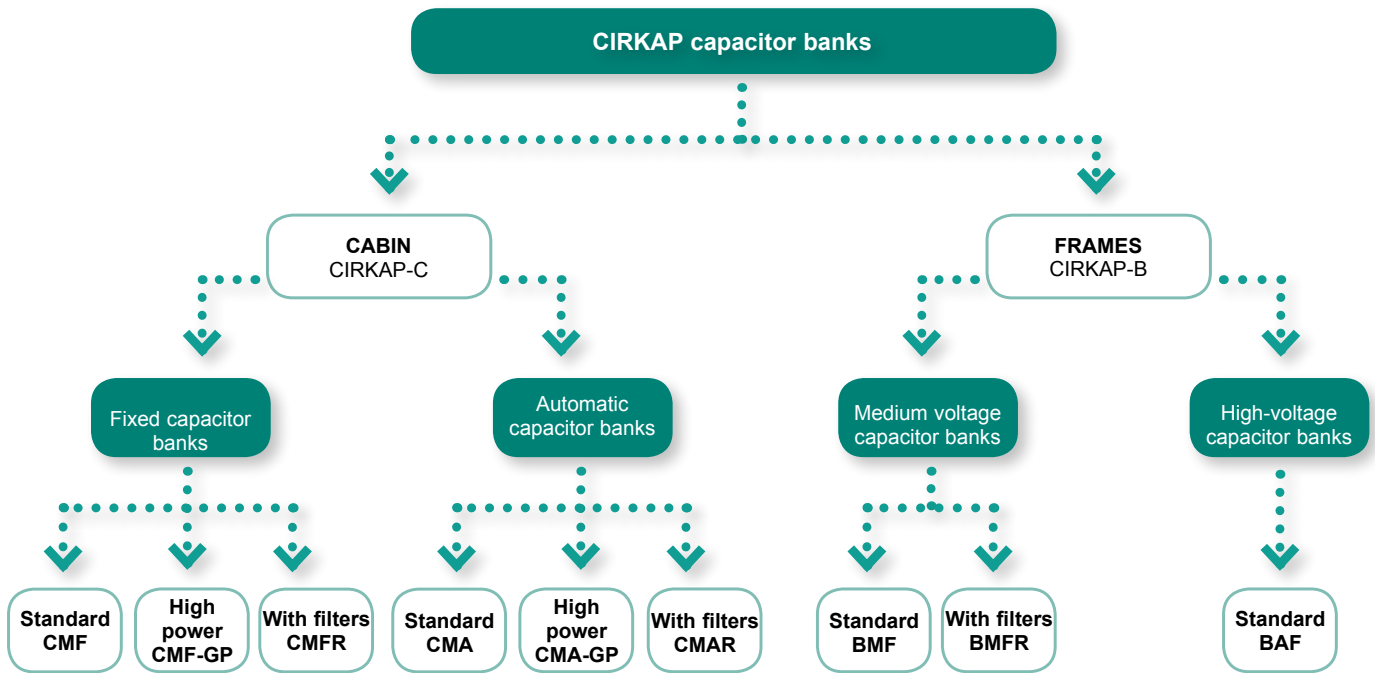

Construction design

Design	<input type="checkbox"/> Cabin	<input type="checkbox"/> Frame
Form of correction	<input type="checkbox"/> Fixed	<input type="checkbox"/> Automatic
Regulation (when it is automatic)	<input type="text"/> kvar	
Location	<input type="checkbox"/> Indoor	<input type="checkbox"/> Outdoor
Type	<input type="checkbox"/> Standard	<input type="checkbox"/> With filters

Electrical parameters

Frequency	<input type="text"/>	Hz
Nominal voltage	<input type="text"/>	kV
Power	<input type="text"/>	kvar
Insulation level (BIL)	<input type="text"/>	kV

Switchgear and protections

Contactors	<input type="checkbox"/> Yes	<input type="checkbox"/> No
Automatic switch	<input type="checkbox"/> Yes	<input type="checkbox"/> No
Cutt off power	<input type="text"/> kA	
Phase protection transformers	<input type="checkbox"/> Yes	<input type="checkbox"/> No
Overload and short-circuit relay	<input type="checkbox"/> Yes	<input type="checkbox"/> No
Earth switch with interlocking	<input type="checkbox"/> Yes	<input type="checkbox"/> No

Information required for installation

More capacitor banks installed	<input type="checkbox"/> Yes	<input type="checkbox"/> No
Power in these capacitor banks	<input type="text"/> kvar	
Existence of harmonics	<input type="checkbox"/> Yes	<input type="checkbox"/> No
Measurement in the case of harmonics	<input type="text"/> kvar	
Short-circuit power	<input type="text"/> MV·A	
Altitude (over sea level)	<input type="text"/> m	
Pollution level	<input type="checkbox"/> Standard	<input type="checkbox"/> Special

Equipment and component definition guide

GENERAL BASIC INFORMATION

1	INSTALLATION	<ul style="list-style-type: none"> • Network voltage (kV) • Network frequency (Hz) • Short-circuit power MV·A • Existence of more capacitor banks (Yes/No) • Existence of harmonics (Yes/No)
2	CAPACITOR BANK	<ul style="list-style-type: none"> • Power of the capacitor bank (kvar) • Capacitor bank voltage (kV) • Fixed / automatic • Type: standard or with filters • General protection requirement (Yes/No) • Location: indoor or outdoor • Other special needs

DEFINITION OF THE CAPACITOR BANK

3	CONFIGURATION	<p>When $U > 11.5$ kV and $Q < 1\,400$ kvar</p> <ul style="list-style-type: none"> • Capacitor bank, three-phase capacitors <p>When $U > 11.5$ and $Q < 1\,400$ kvar or When $U < 11.5$ and $Q > 1\,400$ kvar</p> <ul style="list-style-type: none"> • Double-star capacitor bank, single-phase capacitors
4	DESIGN	<p>Fixed:</p> <ul style="list-style-type: none"> • CMF • BMF <p>Automatic:</p> <ul style="list-style-type: none"> • CMA • Number and power of steps

DEFINITION OF COMPONENTS

5	CAPACITORS	<ul style="list-style-type: none"> • Configuration, single or three-phase • Nominal voltage (kV) • Frequency (Hz) • Insulation level (kV) • Reactive power (kvar) • Special leakage line (mm/kV)
6	REACTORS	<ul style="list-style-type: none"> • Quantity (3 per capacitor bank or step) • Inductance (μH) • Current (A) • Level of insulation (kV) • Short-duration current (kA/1s) • Location: indoor or outdoor

Calculation example

The following example shows the calculation of the basic parameters of a capacitor bank in two scenarios:

Selection of the complete capacitor bank. Selection of the components for the assembly of a capacitor bank To do so, follow the steps defined in the "Equipment and component definition guide"

Capacitor bank selection

5.1. Installation data This installation requires the installation of two capacitor banks, 4 Mvar at 20 kV, on the same substation busbar.

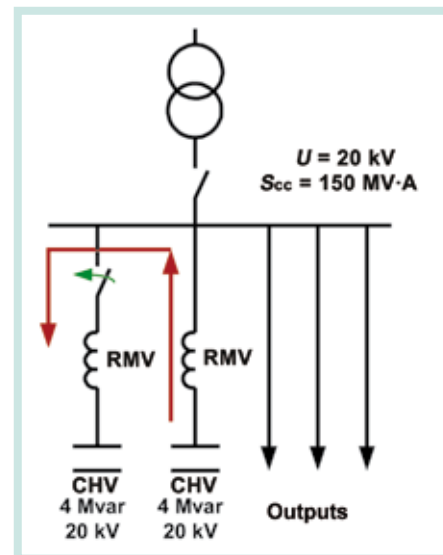

7	SWITCHGEAR	<p>For automatic capacitor banks</p> <ul style="list-style-type: none"> • Contactor $U < 12$ kV • Switch $U > 12$ kV • Capacitive power to cut off (kvar) • Insulation level (kV) • Switch cut off power (kA)
---	------------	--

GENERAL BASIC INFORMATION

1

INSTALLATION

- Network voltage (kV): 20 kV
- Network frequency (Hz): 50 Hz
- Short-circuit power MV·A: 150 MV·A
- Existence of more capacitor banks (Yes/No): NO
- Existence of harmonics (Yes/No): NO

2

CAPACITOR BANK

- Power of the capacitor bank (kvar): 4 Mvar
- Capacitor bank voltage (kV): 20 kV
- Fixed / automatic: Fixed. Control station operations
- Type: standard or with filters: Standard
- Need for General Protection (Yes/No): No. Forecasted protection cabinet
- Location: indoor or outdoor: Indoor
- Other special needs: No

DEFINITION OF THE CAPACITOR BANK

3

CONFIGURATION

$U > 11.5 \text{ kV}$ and $Q > 1\,400 \text{ kvar}$

Double-star capacitor bank, single-phase capacitors.

4

DESIGN

- Fixed, assembled in **CMF24D** type cabin:

Cabin **CMF24D /4000/20**

Selection of components

DEFINITION OF COMPONENTS

5

CAPACITORS

- Single or three-phase configuration: Single-phase (CHV-M)
- Nominal voltage: corresponds to the phase voltage 11.56 kV
- Frequency: 50 Hz

$$Q_{\text{capacitor}} = \frac{Q_{\text{bank}}}{\text{Number of capacitor}} = \frac{4\,000 \text{ kvar}}{\text{Number of capacitor}}$$

- Insulation level: corresponds to the BIL network: 24 kV, 50 / 125 kV
- Power (kvar): The number of capacitors in the unit is calculated

There are two options, 6 or 9 capacitors. The power ratings would be:

For 6 capacitors: 667 kvar
For 9 capacitors: 445 kvar

The second option is selected, with a capacitor power of 450 kvar. Therefore, a double asymmetrical star configuration with 9 capacitors will be used.
- Special leakage line: Clean atmosphere, class 1, 16 mm / kV.

6

REACTORS

There are two possible scenarios:

- Firstly, the connection of a capacitor bank while the other one is disconnected

Secondly, the behaviour of the second capacitor bank while the first one is connected

$$I_p = \sqrt{2} \cdot I_n \cdot \sqrt{\frac{S_{sc}}{Q}} = \sqrt{2} \cdot I_n \cdot \sqrt{\frac{150}{4}} = 8,6 \cdot I_n < 100 \cdot I_n$$

Insulated capacitor bank. Check the peak connection current

Therefore, since the value is under the maximum supported by the Standard, the **RMV** choke REACTORS will not be required.

Capacitor banks in parallel. This is the most unfavourable case. With the formulae given in the choke reactor section (page 16), we can obtain the following results:

- Quantity (3 per capacitor bank or step): 3
- Inductance: 30 μH
- Current: $115,6 \cdot 1,5$ (max. overload coefficient) = 173.4 A. Standardized value 175 A
- Insulation level: corresponds to the BIL network: 24 kV, 50/125 kV (need for additional insulation elements)
- Short-duration current (kA/1s): $43 I_n$
- Location: indoor or outdoor: Indoor

7

SWITCHGEAR

In this example, the capacitor banks do not include the switchgear, but there is information provided for the designer, for the correct definition of the general protection cabin:

- Automatic switch: 400 or 630 A. Recommended interruption method: vacuum or SF6
- Capacitive power interrupted (kvar): 4 000 kvar
- Insulation level (kV): 24 kV
- Interrupting power of the switch (kA): 12.5 kA

CHV-M

Single-phase capacitor (indoor and outdoor use)



Description

The **CHV** Medium Voltage capacitors are composed of different capacitive elements.

These basic units are connected in series and parallel with the purpose of obtaining the power at the necessary voltage.

All elements are protected with an internal fuse that will be disconnected in case of a fault, isolating the basic unit damaged.

The protection with internal fuses will increase the security of the system and continuity of the service.

Application

CHV-M capacitors are used to build fixed and automatic MV capacitor banks.

We will vary the number of capacitors in parallel and/or in series, depending on the power and voltage levels required.

Its stainless steel box means that the **CHV** capacitor is versatile and can be used in indoor and outdoor applications.

Features

Voltage	1 ... 20 kV
Nominal power	25 ... 600 kvar
Frequency	50 or 60 Hz
Dielectric losses	≤ 0.2 W / kvar
Capacity tolerance	-5 ... +10 %
Location	Indoor / Outdoor
Protection	Internal fuse (depending on the type)
Discharge resistance (in compliance with IEC 60871-1)	
Location	Indoor
Discharge time	≤ 10 minutes
Residual voltage	≤ 75 V
Insulators	
Material	Porcelain
Pollution level	16 mm / kV (other leakage lines, on demand)
Insulation level	12 - 17.5 - 24 - 36 kV (see table 1)
Overload	
In current	1.3 I_n permanent
In voltage	1.1 U_n 12 h in 24 hours
	1.15 U_n 30 min in 24 hours
	1.2 U_n 5 min in 24 hours
	1.30 U_n 1 min in 24 hours
Ambient conditions	
Operating temperature	Category C (in accordance with IEC 60871-1)
Maximum temperature (*2)	50° C
Maximum mean value during 24 hours	40° C
Maximum mean value during 1 year	30° C
Build features	
Dielectric	Rough polypropylene film
Electrode	Aluminium sheet
Impregnating oil	SAS-40E or M/DBT (PCB-free)
Dimensions (mm)	depending on the type
Weight	depending on the type (see table)
Box	Painted stainless steel, RAL 7035 2 wings to fix to the frame and avoid mechanical efforts on porcelain terminals
Assembly position	Horizontal or vertical
Standards	
IEC 60871-1, IEC 60871-4	

(*2) Understood as punctual

CHV-M

Single-phase capacitor (indoor and outdoor use)



Dimensions

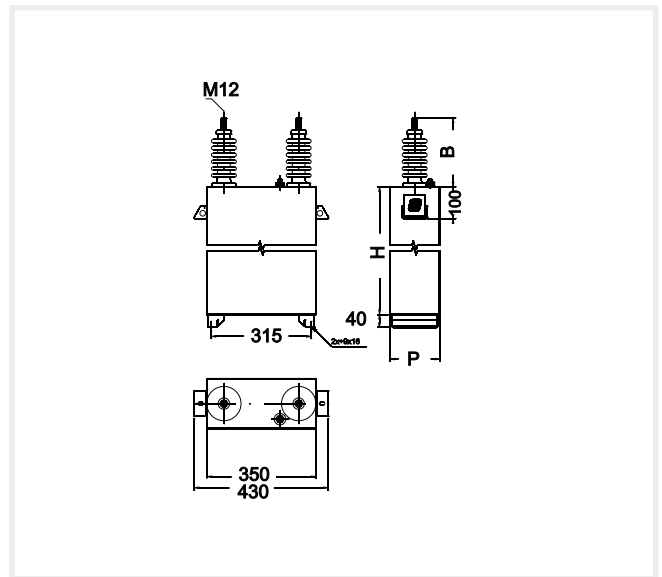

References

BIL: 28 / 75 kV - 6.6 kV (Network 11 kV), 50 Hz

kvar	Weight (kg)	Dimensions (mm) width x height x depth	Type	Code
50	17	350 x 405 x 160	CHV-M 50 / 6.6(*)	R80193
75	20	350 x 455 x 160	CHV-M 75 / 6.6(*)	R80195
100	22	350 x 505 x 160	CHV-M 100 / 6.6	R80196
133	25	350 x 565 x 160	CHV-M 133 / 6.6	R80197
150	28	350 x 615 x 160	CHV-M 150 / 6.6	R80198
167	30	350 x 615 x 160	CHV-M 167 / 6.6	R80199
200	34	350 x 675 x 160	CHV-M 200 / 6.6	R8019A
250	40	350 x 785 x 160	CHV-M 250 / 6.6	R8019B
300	46	350 x 775 x 175	CHV-M 300 / 6.6	R8019C
400	57	350 x 915 x 175	CHV-M 400 / 6.6	R8019F
500	68	350 x 1055 x 175	CHV-M 500 / 6.6	R8019G
600	79	350 x 1165 x 220	CHV-M 600 / 6.6	R8019H

BIL: 38 / 95 kV - 8 kV (Network 13.2 kV), 50 Hz

kvar	Weight (kg)	Dimensions (mm) width x height x depth	Type	Code
50	19	350 x 470 x 160	CHV-M 50 / 8(*)	R801B3
75	23	350 x 520 x 160	CHV-M 75 / 8(*)	R801B5
100	25	350 x 570 x 160	CHV-M 100 / 8(*)	R801B6
133	28	350 x 620 x 160	CHV-M 133 / 8	R801B7
150	31	350 x 680 x 160	CHV-M 150 / 8	R801B8
167	33	350 x 680 x 160	CHV-M 167 / 8	R801B9
200	38	350 x 740 x 160	CHV-M 200 / 8	R801BA
250	43	350 x 850 x 160	CHV-M 250 / 8	R801BB
300	49	350 x 940 x 160	CHV-M 300 / 8	R801BC
400	61	350 x 1010 x 175	CHV-M 400 / 8	R801BF
500	70	350 x 1190 x 175	CHV-M 500 / 8	R801BG
600	81	350 x 1230 x 175	CHV-M 600 / 8	R801BH

CHV-M

Single-phase capacitor (indoor and outdoor use)

**References**

BIL: 38 / 95 kV - 9.1 kV (Network 15 kV). 50 Hz

kvar	Weight (kg)	Dimensions (mm) width x height x depth	Type	Code
50	19	350 x 470 x 160	CHV-M 50 / 9.1(*)	R801D3
75	23	350 x 520 x 160	CHV-M 75 / 9.1(*)	R801D5
100	25	350 x 570 x 160	CHV-M 100 / 9.1(*)	R801D6
133	28	350 x 620 x 160	CHV-M 133 / 9.1	R801D7
150	31	350 x 620 x 160	CHV-M 150 / 9.1	R801D8
167	33	350 x 680 x 160	CHV-M 167 / 9.1	R801D9
200	38	350 x 740 x 160	CHV-M 200 / 9.1	R801DA
250	43	350 x 850 x 160	CHV-M 250 / 9.1	R801DB
300	49	350 x 860 x 160	CHV-M 300 / 9.1	R801DC
400	61	350 x 1010 x 175	CHV-M 400 / 9.1	R801DF
500	70	350 x 1160 x 175	CHV-M 500 / 9.1	R801DG
600	81	350 x 1230 x 200	CHV-M 600 / 9.1	R801DH

(*) No internal fuses

BIL: 50 / 125 kV - 12.1 kV (Network 20 kV). 50 Hz

kvar	Weight (kg)	Dimensions (mm) width x height x depth	Type	Code
50	19	350 x 510 x 160	CHV-M 50 / 12.1(*)	R801F3
75	23	350 x 560 x 160	CHV-M 75 / 12.1(*)	R801F5
100	25	350 x 620 x 160	CHV-M 100 / 12.1(*)	R801F6
133	28	350 x 660 x 160	CHV-M 133 / 12.1(*)	R801F7
150	31	350 x 720 x 160	CHV-M 150 / 12.1(*)	R801F8
167	33	350 x 780 x 160	CHV-M 167 / 12.1	R801F9
200	38	350 x 890 x 160	CHV-M 200 / 12.1	R801FA
250	43	350 x 890 x 160	CHV-M 250 / 12.1	R801FB
300	49	350 x 900 x 175	CHV-M 300 / 12.1	R801FC
400	61	350 x 1090 x 175	CHV-M 400 / 12.1	R801FF
500	70	350 x 1230 x 175	CHV-M 500 / 12.1	R801FG
600	81	350 x 1270 x 200	CHV-M 600 / 12.1	R801FH

CHV-M

Single-phase capacitor (indoor and outdoor use)

References

BIL: 70 / 170 kV - 15.2 kV (Network 25 kV). 50 Hz

kvar	Weight (kg)	Dimensions (mm) width x height x depth	Type	Code
50	19	350 x 510 x 145	CHV-M 50 / 15.2(*)	R801H3
75	23	350 x 590 x 145	CHV-M 75 / 15.2(*)	R801H5
100	25	350 x 590 x 145	CHV-M 100 / 15.2(*)	R801H6
133	28	350 x 670 x 145	CHV-M 133 / 15.2(*)	R801H7
150	31	350 x 670 x 145	CHV-M 150 / 15.2(*)	R801H8
167	33	350 x 760 x 145	CHV-M 167 / 15.2(*)	R801H9
200	38	350 x 760 x 145	CHV-M 200 / 15.2(*)	R801HA
250	43	350 x 860 x 145	CHV-M 250 / 15.2	R801HB
300	49	350 x 940 x 145	CHV-M 300 / 15.2	R801HC
400	61	350 x 980 x 175	CHV-M 400 / 15.2	R801HF
500	70	350 x 1120 x 175	CHV-M 500 / 15.2	R801HG
600	81	350 x 1260 x 175	CHV-M 600 / 15.2	R801HH

BIL: 70/170 kV - 18.2 V (Network 30 kV). 50 Hz

kvar	Weight (kg)	Dimensions (mm) width x height x depth	Type	Code
50	19	350 x 510 x 145	CHV-M 50 / 18.2(*)	R801J3
75	23	350 x 590 x 145	CHV-M 75 / 18.2(*)	R801J5
100	25	350 x 590 x 145	CHV-M 100 / 18.2(*)	R801J6
133	28	350 x 670 x 145	CHV-M 133 / 18.2(*)	R801J7
150	31	350 x 670 x 145	CHV-M 150 / 18.2(*)	R801J8
167	33	350 x 760 x 145	CHV-M 167 / 18.2(*)	R801J9
200	38	350 x 760 x 145	CHV-M 200 / 18.2(*)	R801JA
250	43	350 x 860 x 145	CHV-M 250 / 18.2(*)	R801JB
300	49	350 x 940 x 145	CHV-M 300 / 18.2	R801JC
400	61	350 x 980 x 175	CHV-M 400 / 18.2	R801JF
500	70	350 x 1120 x 175	CHV-M 500 / 18.2	R801JG
600	81	350 x 1260 x 175	CHV-M 600 / 18.2	R801JH

(*) No internal fuses

CHV-T

Three-phase capacitor (Indoor use, with fuses and discharge resistor, internal)



Description

The **CHV** Medium Voltage capacitors are composed of different capacitive elements.

These basic units are connected in series and parallel with the purpose of obtaining the power at the necessary voltage.

All elements are protected with an internal fuse that will be disconnected in case of a fault, isolating the basic unit damaged.

The protection with internal fuses will increase the security of the system and continuity of the service.

Application

CHV-T capacitors are used to build fixed and automatic capacitor banks of up to 12 kV.

The stainless steel box of the **CHV-T** makes it a versatile product that can be used in indoor and outdoor applications.

Features

Voltage	1 ... 12 kV
Nominal power	25 ... 500 kvar
Frequency	50 or 60 Hz
Dielectric losses	≤ 0.2 W / kvar
Capacity tolerance	-5 ... +10 %
Location	Indoor / Outdoor
Protection	Internal fuse (depending on the type)
Discharge resistance (in compliance with IEC 60871-1)	
Location	Indoor
Discharge time	≤ 10 minutes
Residual voltage	≤ 75 V
Insulators	
Material	Porcelain
Pollution level	16 mm / kV (other leakage lines, on demand)
Insulation level	12 - 17.5 - 24 - 36 kV (see table 1)
Overload	
In current	$1.3 I_n$ permanent
In voltage	$1.1 U_n$ 12 h in 24 hours $1.15 U_n$ 30 min in 24 hours $1.2 U_n$ 5 min in 24 hours $1.30 U_n$ 1 min in 24 hours
Ambient conditions	
Operating temperature	Category C (in accordance with IEC 60871-1)
Maximum temperature (*2)	50 °C
Maximum mean value during 24 hours	40 °C
Maximum mean value during 1 year	30 °C
Build features	
Dielectric	Rough polypropylene film
Electrode	Aluminium sheet
Impregnating oil	SAS-40E or M/DBT (PCB-free)
Dimensions (mm)	depending on the type
Weight	depending on the type (see table)
Box	Painted stainless steel, RAL 7035 2 wings to fix to the frame and avoid mechanical efforts on porcelain terminals
Assembly position	Horizontal or vertical
Standards	
IEC 60871-1, IEC 60871-4	

(*2) Understood as punctual

CHV-T

Three-phase capacitor (Indoor use, with fuses and discharge resistor, internal)



Dimensions

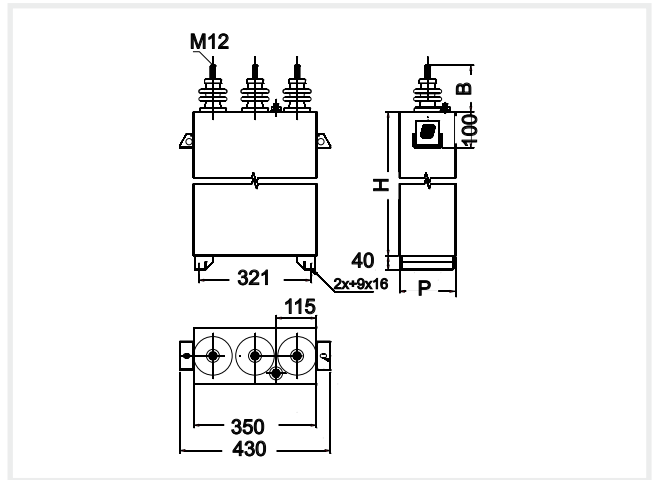

References

BIL: 20 / 60 kV - 3.3 kV . 50 Hz

kvar	Weight (kg)	Dimensions (mm) width x height x depth	Type	Code
50	17	350 x 405 x 160	CHV-T 50 /3.3	R80223
75	20	350 x 455 x 160	CHV-T 75 /3.3	R80225
100	22	350 x 505 x 160	CHV-T 100 /3.3	R80226
150	28	350 x 555 x 160	CHV-T 150 /3.3	R80228
200	34	350 x 675 x 160	CHV-T 200 /3.3	R8022A
250	40	350 x 785 x 160	CHV-T 250 /3.3	R8022B
300	46	350 x 875 x 160	CHV-T 300 /3.3	R8022C
400	57	350 x 915 x 175	CHV-T 400 /3.3	R8022F
500	68	350 x 1055 x 175	CHV-T 500 /3.3	R8022G

BIL: 20 / 60 kV - 6.6 kV . 50 Hz

kvar	Weight (kg)	Dimensions (mm) width x height x depth	Type	Code
50	17	350 x 405 x 160	CHV-T 50 /6.6	R80283
75	20	350 x 455 x 160	CHV-T 75 /6.6	R80285
100	22	350 x 505 x 160	CHV-T 100 /6.6	R80286
150	28	350 x 615 x 160	CHV-T 150 /6.6	R80288
200	34	350 x 675 x 160	CHV-T 200 /6.6	R8028A
250	40	350 x 785 x 160	CHV-T 250 /6.6	R8028B
300	46	350 x 875 x 160	CHV-T 300 /6.6	R8028C
350	53	350 x 945 x 160	CHV-T 350 /6.6	R8028D
400	57	350 x 1015 x 175	CHV-T 400 /6.6	R8028F
500	68	350 x 1165 x 175	CHV-T 500 /6.6	R8028G

BIL: 28 / 75 kV - 11 kV

kvar	Weight (kg)	Dimensions (mm) width x height x depth	Type	Code
50	17	350 x 405 x 160	CHV-T 50 /11	R802B3
75	20	350 x 455 x 160	CHV-T 75 /11	R802B5
100	22	350 x 455 x 160	CHV-T 100 /11	R802B6
150	28	350 x 555 x 160	CHV-T 150 /11	R802B8
200	34	350 x 675 x 160	CHV-T 200 /11	R802BA
250	40	350 x 785 x 160	CHV-T 250 /11	R802BB
300	46	350 x 875 x 160	CHV-T 300 /11	R802BC
350	53	350 x 945 x 160	CHV-T 350 /11	R802BD
400	57	350 x 915 x 175	CHV-T 400 /11	R802BF
500	68	350 x 1055 x 175	CHV-T 500 /11	R802BG

LVC

Three-phase contactor for MV capacitors.



Description

The **LVC** contactor is a vacuum contactor prepared to control inductive and capacitive loads.

Application

The **LVC** contactor has been specially designed for industrial applications that require a large number of switching operations. In particular, the loads from motors and capacitors.

The **LVC** vacuum contactor is ideal for the switching operations of capacitor banks between 3.3 and 6.6 kV.

Its general features are as follows:

- Interrupting methods, vacuum
- Total control of the electric arc in capacitive switching operations
- Very long working life
- Heavy insulation of the set, composed of three independent vacuum poles, assembled on an insulating structure
- Small size
- Light unit, greatly optimised weight
- Easy to maintain

Features

Features	
Auxiliary voltage	220 V ac / 110 V dc (on demand)
Nominal voltage	6.6 kV
Nominal current	400 A
Interrupting power	4 kA
Frequency	50 ... 60 Hz
Insulation level	
Category	AC 3
No. of operations	300 000
Maximum operation power	2 000 kvar at 6.6 kV
Build features	
Connection	Fixed
Dimensions	350 x 392 x 179 mm
Weight	22 kg
Standard	
IEC60470	

Dimensions

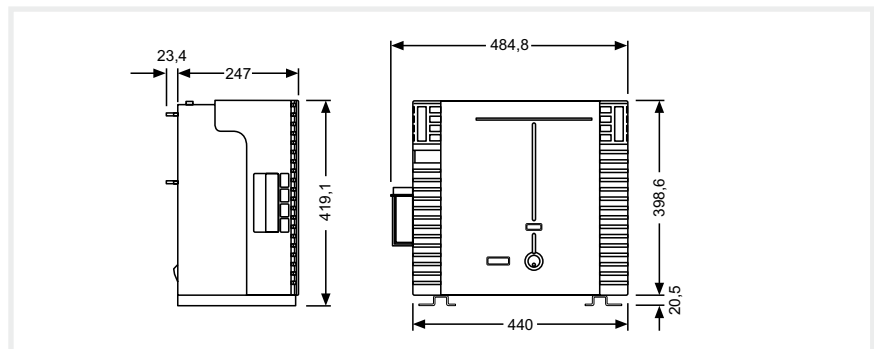

References

Maximum operating voltage	Maximum current	Type	Auxiliary voltage	Code
6.6 kV ac	3 x 400 A	LVC-6Z44ED	220 V ac	R80911
6.6 kV ac	3 x 400 A	LVC-6Z44ED	110 V dc	R809110010000

RMV

Choke reactor for capacitor banks



Description

Choke REACTORS are required to limit the transient currents produced during the connection of capacitors.

CIRCUTOR's **RMV** units are encapsulated in epoxy resin, which guarantees the degree of insulation required.

Application

The connection of capacitor banks has very high associated transient currents and voltages.

The **IEC 60871-1** Standard defines the maximum value that can be supported by a capacitor bank as the peak connection value. This value is 100 times its nominal current.

When this value is exceeded, **RMV** choke REACTORS must be installed. These REACTORS are in charge of limiting the transient current to values that can be supported by the capacitors. The inductance value is variable, depending on the installation's conditions and, basically, on the following parameters:

- Short-circuit power of the installation
- Existence of more capacitor banks
- Interrupting power of automatic switches.

The peak current value of the residual connection must also be lower than the interrupting power of the switch unit after the reactor has been installed

Features

Features	
Short-duration nominal current	43 I_n / 1 s
Dynamic current	2.5 I_t
Insulation level	12 kV (28/75)
Ambient conditions	
Operating temperature	Category B
Mean temperature	40 °C
Build features	
Type	Encapsulated in resin Air core
Fittings	M12 / M16, depending on the type
Dimensions (mm)	depending on the type
Weight	depending on the type (see table on the top)
Colour	colour RAL 8016
Standard	
IEC60289	

RMV

Choke reactor for capacitor banks

Dimensions

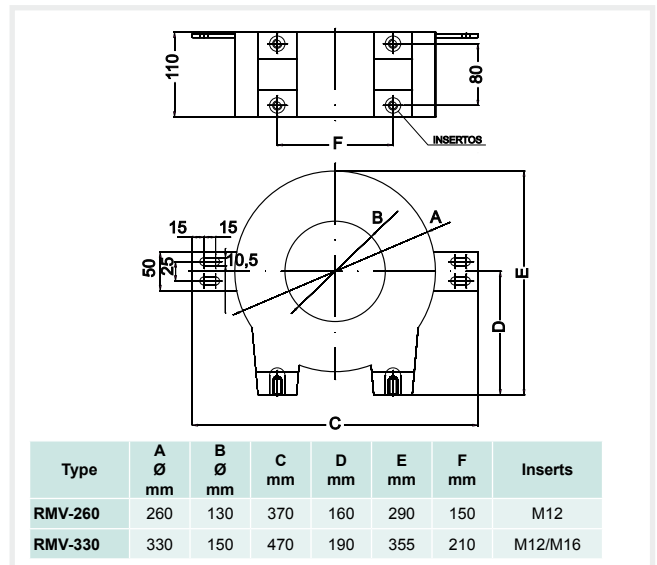

References

RMV-260

I (A)	L (µH)	Weight (kg)	Type	Code
50	350	13	RMV - 260 - 50 - 350	R80628
60	250	14	RMV - 260 - 60 - 250	R80637
100	100	16	RMV - 260 - 100 - 100	R80664
125	50	14	RMV - 260 - 125 - 50	R80672
175	30	14	RMV - 260 - 175 - 30	R80691

RMV-330

I (A)	L (µH)	Weight (kg)	Type	Code
60	450	20	RMV - 330 - 60 - 450	R80739
75	350	21	RMV - 330 - 75 - 350	R80748
90	250	26	RMV - 330 - 90 - 250	R80757
125	100	22	RMV - 330 - 125 - 100	R80774
200	50	22	RMV - 330 - 200 - 50	R807A2
250	30	23	RMV - 330 - 250 - 30	R807B1

The RMV reactor selection parameters are:

* Maximum working current (1.43 times I_n of the unit)

* Inductance required in µH

* Insulation voltage kV

The insulation voltage is 12 kV (28/75). Other voltages, on demand

The thermal current is 43 I_n / 1 s. Other values, on demand

CIRKAP-C

Fixed or automatic capacitor banks in cabinet

Description

The installation of the capacitor banks of the **CIRKAP-C** series offers the following advantages:

- Protection against direct contacts of active parts
- Space economy. The use of no security enclosures and use of internal fuses allows the designers to greatly reduce the dimensions of the unit
- Optional addition of switchgear to protect the capacitor bank or perform automatic equipment functions



Application

The most common applications are:

Medium Voltage industrial networks

- Compensation of large motors. Usually 3 to 11 kV
- Compensation of HV / MV transformers
- Fixed or automatic compensation of the following installations: cement plants, pumping stations, pipelines, mining, paper industry.

Generation and distribution systems

- Receiving and distributing stations. Particularly indoor installations, where the use of space is vital
- Generation stations that need an automatic power factor regulation: small-scale hydraulic power plants, wind farms, etc.

Features

Voltage	1 ... 36 kV
Nominal power	100 ... 14,000 kvar
Frequency	50 or 60 Hz
Location	Indoor / Outdoor
Degree of protection	IP 23 (Other values, on demand)
Insulation level	7.2 ... 36 kV
Setup	
Capacitors	three or single-phase, double star arrangement (depending on the type)
Capacitor bank	Fixed or automatic
Build features	
Dimensions (mm)	depending on the type
Weight	depending on the type
Panels and frames	Painted steel RAL 7035 For outdoor use, treated and painted steel

References

Shape	Types	Power (kvar) (*)	Insulation levels				
			7.2 kV	12 kV	17.5 kV	24 kV	36 kV
Fixed	Standard	100 ...7200	CMF7T CMF7D	CMF12T CMF12D	CMF17D	CMF24D	CMF36D
	High power	1800...14000		CMF12GP	CMF17GP	CMF24GP	CMF36GP
	With detuned filters	100...7200	CMFR7T CMFR7D	CMFR12D	CMFR17D	CMFR24D	
Automatic	Standard	100...8000	CMA7T CMA7D	CMA12T CMA12D	CMA17D	CMA24D	CMA36D
	High power	1800...14000		CMA12GP	CMA17GP	CMA24GP	CMA36GP
	With detuned filters	100...7200	CMAR7T CMAR7D	CMAR12D	CMAR17D	CMAR24D	

(Maximum power per step)
* Other power ratings, please ask

Type of capacitor ... T three-phase
... D single-phase

CIRKAP-C

Fixed or automatic capacitor banks in cabinet

Dimensions

Dimensions are approximate and could be different depending on the power, voltage and place of location

Cabinet with 2 capacitors

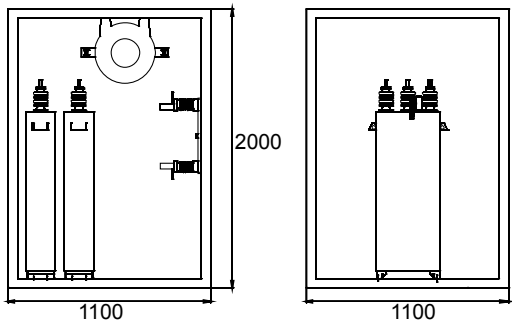

Cabinet with 4 capacitors

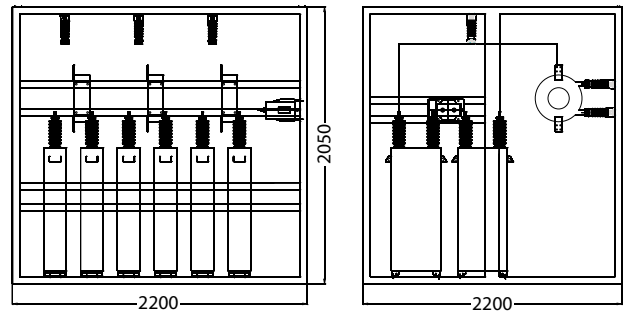
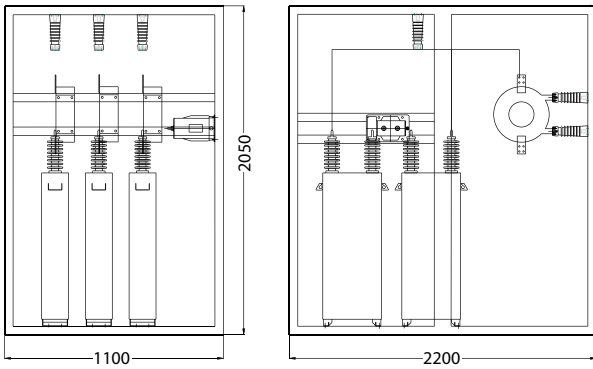
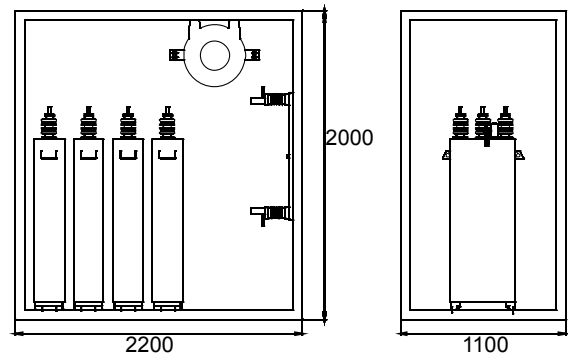

CIRKAP-C

Fixed or automatic capacitor banks in cabinet

Dimensions

Dimensions are approximate and could be different depending on the power, voltage and place of location

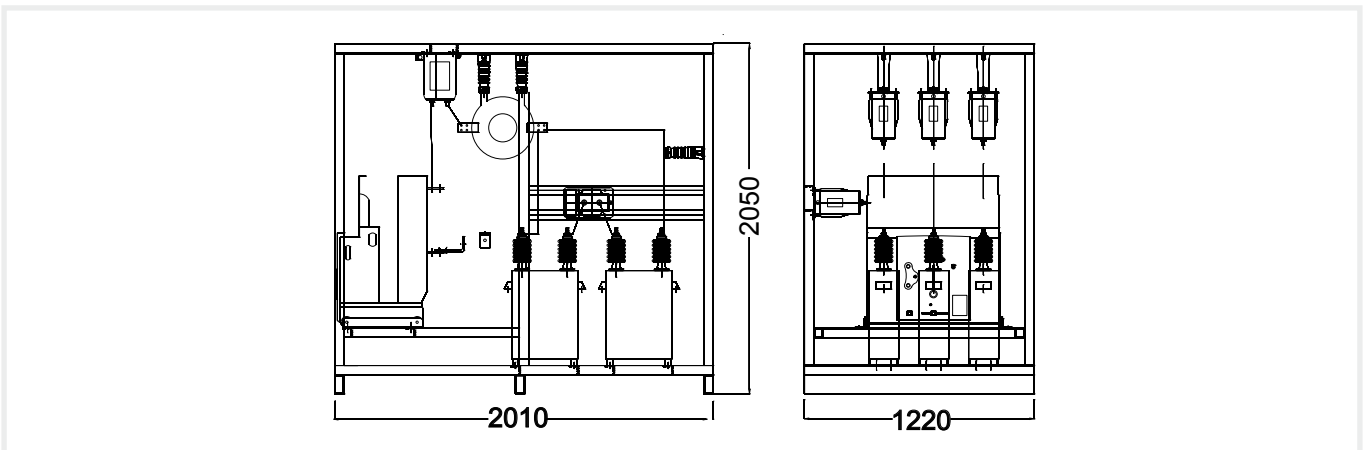
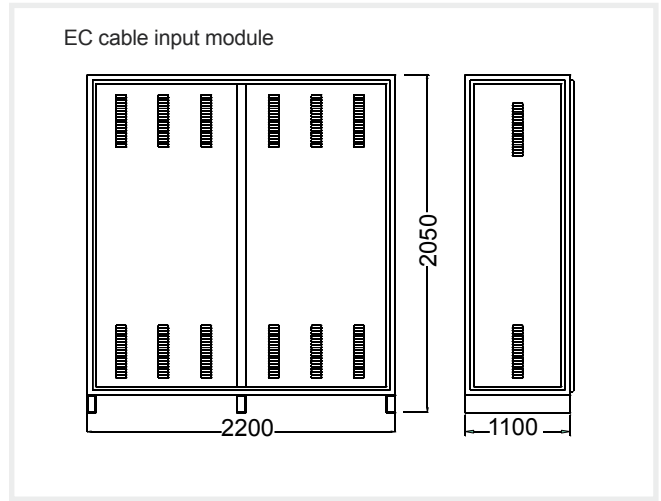
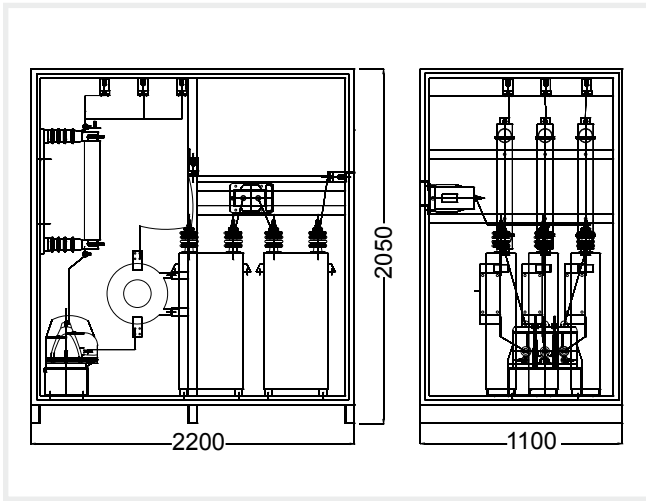
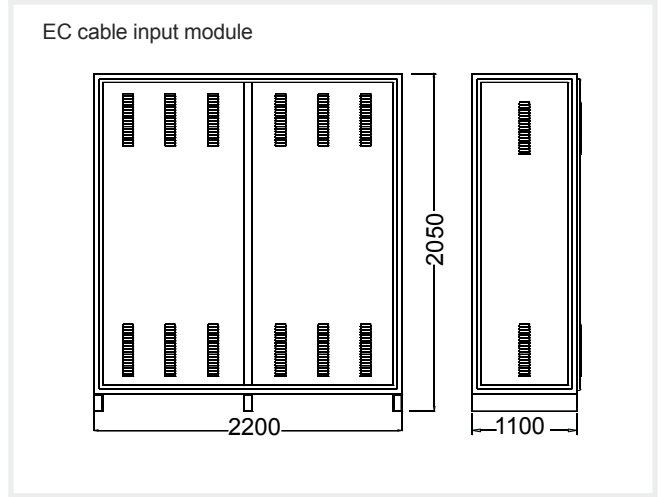
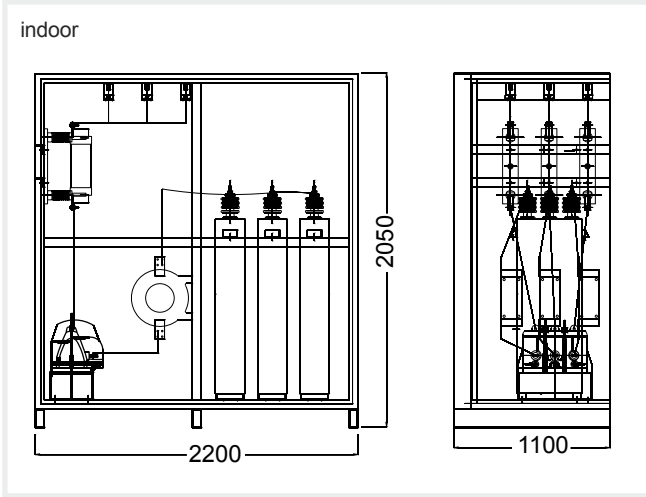

CIRKAP-GP

High-powered capacitor banks in cabinet

Description

The **CIRKAP-GP** capacitor banks have been specially designed for the distribution of electrical energy, where the use of medium-powered capacitors is common (300 ... 350 kvar) in reduced spaces.

There are two versions, as in the whole range of capacitor banks:

- Fixed: Type **CMF-GP**
- Automatic or with general protection: Type **CMA-GP**

Features

	CMF-GP	CMA-GP
Voltage	20 ... 30 kV	
Maximum power	8 Mvar	
Frequency	50 or 60 Hz	
Location	Indoor / Outdoor	
Degree of protection	IP 23	IP54
Insulation level	24 / 36 kV	
Setup		
Capacitors	single-phase in a double-star arrangement	
Capacitor bank	Fixed	Automatic
Build features		
Dimensions (mm)	depending on the type	
Weight	depending on the type	
Panels and frames	Painted steel. For outdoor use, treated and painted steel	
capacity for:	<ul style="list-style-type: none"> •24 capacitors CHV-M •Choke REACTORS RMV •Earthing selector •Unbalance transformer 	<ul style="list-style-type: none"> •24 capacitors CHV-M •Choke REACTORS RMV •Earthing selector plus interlocking •Automatic switch •Phase protection transformer •Unbalance transformer

CIRKAP-CMFR / CMAR

Fixed or automatic capacitor banks in cabinet with detuned filters

Description

The capacitor banks must be equipped with detuned filters when there is a high level of harmonics.

In this case, **CIRCUTOR** recommends the use of automatic **CMFR** or **CMAR** capacitor banks, equipped with iron core REACTORS and synchronised capacitors, up to 7% of the insulation voltages of 7.2 kV.

For higher voltage levels, air core technology is used in these REACTORS



CIRKAP-B

Capacitor banks in frames



Description

The capacitor banks in frames are composed of the following:

- Capacitors
- Unbalance transformers
- After 36 kV, the capacitor banks are designed with a frame per phase, with the adequate support insulators of the insulation level, in accordance with the network's service voltage.

Optional:

- Choke REACTORS **RMV**
- Quick discharge REACTORS

Application

The capacitor banks in frames are common in distribution substations and, particularly, in High Voltage applications.

They can be used in any type of installation, but the use of enclosures or lifting support units is required to avoid the contact with active parts.

Features

Voltage	7.2 ... 33 kV
Nominal power	600 ... 7200 kvar
Frequency	50 or 60 Hz
Location	Indoor / Outdoor
Degree of protection	IP 00
Insulation level	7.2 ... 33 kV
Setup	
Capacitors	single-phase in a double-star arrangement
Capacitor bank	Fixed
Build features	
Dimensions (mm)	depending on the type
Weight	depending on the type
Panels and frames	Treated and painted steel

References

Capacitor banks for MV, in frame (max. 7 200 kvar)	
13.8 kV at 15 kV	BMF17D
20 kV at 22 kV	BMF24D
25 kV at 30 kV	BMF36D
Capacitor banks for MV, in frame, with detuned filters	
7.2 kV	BMFR
Capacitor banks for HV, in frame	
52.5 kV at 123 kV	BAF

Dimensions

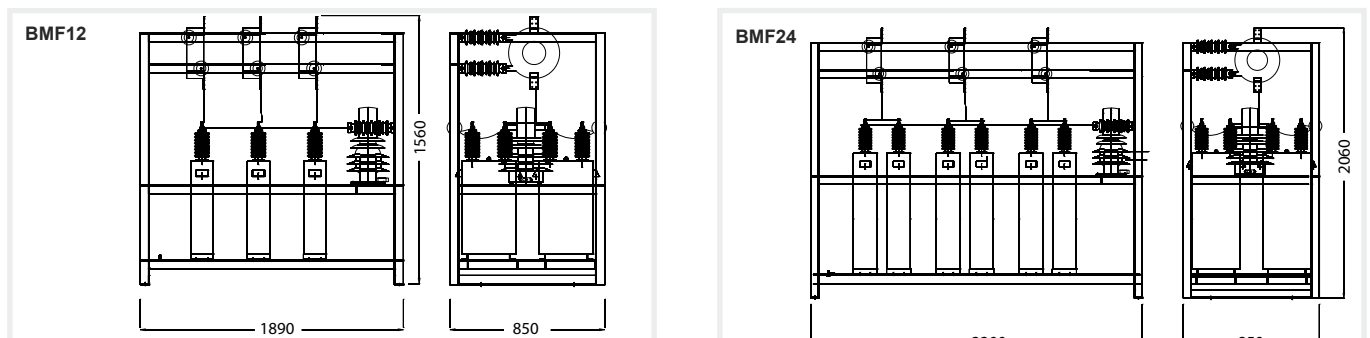

Dimensions are approximate and could be different depending on the power, voltage and place of location

R.8/9

MV capacitors banks and accessories